

RESEARCH ARTICLE

On Approach to Increase Integration Rate of Elements of a Switched-capacitor Step-down DC-DC Converter

E. L. Pankratov^{1,2}

¹ Department of Mathematics, Nizhny Novgorod State University, 23 Gagarin Avenue, Nizhny Novgorod, 603950, Russia, ²Department of Mathematics, Nizhny Novgorod State Technical University, 24 Minin Street, Nizhny Novgorod, 603950, Russia

Received: 15-05-2020; Revised: 01-06-2020; Accepted: 20-07-2020

ABSTRACT

In this paper, we introduce an approach to increase integration rate of elements of a switched-capacitor step-down DC–DC converter. Framework the approach, we consider a heterostructure with special configuration. Several specific areas of the heterostructure should be doped by diffusion or ion implantation. Annealing of dopant and/or radiation defects should be optimized.

Key words: Switched-capacitor step-down DC–DC converter, optimization of manufacturing, analytical approach for modeling

INTRODUCTION

An actual and intensively solving problem of solid-state electronics is increasing of integration rate of elements of integrated circuits (p - n -junctions, their systems *et al.*).^[1-8] Increasing of the integration rate leads to necessity to decrease their dimensions. To decrease, the dimensions are using several approaches. They are widely using laser and microwave types of annealing of infused dopants. These types of annealing are also widely using for annealing of radiation defects, generated during ion implantation.^[9-17] Using the approaches gives a possibility to increase integration rate of elements of integrated circuits through inhomogeneity of technological parameters due to generating inhomogenous distribution of temperature. In this situation, one can obtain decreasing dimensions of elements of integrated circuits^[18] with account Arrhenius law.^[1,3] Another approach to manufacture elements of integrated circuits with smaller dimensions is doping of heterostructure by diffusion or ion implantation.^[1-3] However, in this case, optimization of dopant and/or radiation defects is required.^[18]

In this paper, we consider a heterostructure. The heterostructure consists of a substrate and several epitaxial layers. Some sections have been manufactured in the epitaxial layers. Further, we consider doping of these sections by diffusion or ion implantation. The doping gives a possibility to manufacture field-effect transistors framework a cascaded inverter circuit so as it is shown in Figure 1. The manufacturing gives a possibility to increase density of elements of the switched-capacitor step-down DC-DC converter.^[4] After the considered doping, dopant and/or radiation defects should be annealed. Framework the paper, we analyzed dynamics of redistribution of dopant and/or radiation defects during their annealing. We introduce an approach to decrease dimensions of the element. However, it is necessary to complicate technological process.

METHOD OF SOLUTION

In this section, we determine spatiotemporal distributions of concentrations of infused and implanted dopants. To determine these distributions, we calculate appropriate solutions of the second Fick's law.^[1,3,18]

Address for correspondence:

E. L. Pankratov

E-mail: elp2004@mail.ru

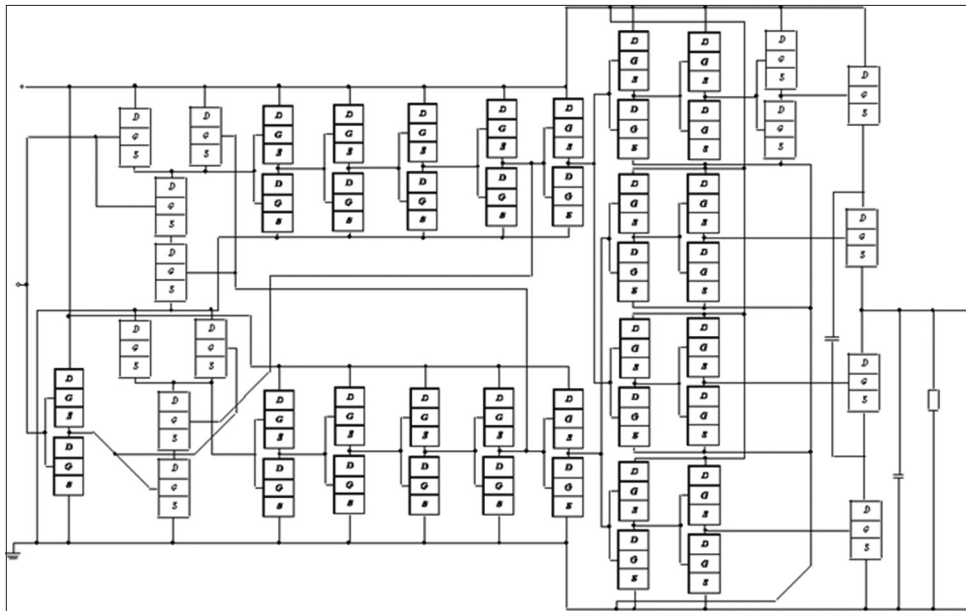

Figure 1: The considered cascaded inverter^[4]

$$\frac{\partial C(x, y, z, t)}{\partial t} = \frac{\partial}{\partial x} \left[D_c \frac{\partial C(x, y, z, t)}{\partial x} \right] + \frac{\partial}{\partial y} \left[D_c \frac{\partial C(x, y, z, t)}{\partial y} \right] + \frac{\partial}{\partial z} \left[D_c \frac{\partial C(x, y, z, t)}{\partial z} \right] \quad (1)$$

Boundary and initial conditions for the equations are

$$\begin{aligned} \left. \frac{\partial C(x, y, z, t)}{\partial x} \right|_{x=0} = 0, \quad \left. \frac{\partial C(x, y, z, t)}{\partial x} \right|_{x=L_x} = 0, \quad \left. \frac{\partial C(x, y, z, t)}{\partial y} \right|_{y=0} = 0, \quad \left. \frac{\partial C(x, y, z, t)}{\partial y} \right|_{x=L_y} = 0, \\ \left. \frac{\partial C(x, y, z, t)}{\partial z} \right|_{z=0} = 0, \quad \left. \frac{\partial C(x, y, z, t)}{\partial z} \right|_{x=L_z} = 0, \quad C(x, y, z, 0) = f(x, y, z). \end{aligned} \quad (2)$$

The function $C(x, y, z, t)$ describes the spatiotemporal distribution of concentration of dopant; T is the temperature of annealing; D_c is the dopant diffusion coefficient. Value of dopant diffusion coefficient could be changed with changing materials of heterostructure, with changing temperature of materials (including annealing), with changing concentrations of dopant and radiation defects. We approximate dependences of dopant diffusion coefficient on parameters by the following relation with account results in Refs.^[20-22]

$$D_c = D_L(x, y, z, T) \left[1 + \xi \frac{C^\gamma(x, y, z, t)}{P^\gamma(x, y, z, T)} \right] \left[1 + \zeta_1 \frac{V(x, y, z, t)}{V^*} + \zeta_2 \frac{V^2(x, y, z, t)}{(V^*)^2} \right] \quad (3)$$

Here, the function $D_L(x, y, z, T)$ describes the spatial (in heterostructure) and temperature (due to Arrhenius law) dependences of diffusion coefficient of dopant. The function $P(x, y, z, T)$ describes the limit of solubility of dopant. Parameter $\gamma \in [1, 3]$ describes average quantity of charged defects interacted with atom of dopant.^[20] The function $V(x, y, z, t)$ describes the spatiotemporal distribution of concentration of radiation vacancies. Parameter V^* describes the equilibrium distribution of concentration of vacancies. The considered concentrational dependence of dopant diffusion coefficient has been described in details in.^[20] It should be noted that using diffusion type of doping did not generation radiation defects. In this situation, $\zeta_1 = \zeta_2 = 0$. We determine spatiotemporal distributions of concentrations of radiation defects by solving the following system of equations.^[21, 22]

$$\frac{\partial I(x, y, z, t)}{\partial t} = \frac{\partial}{\partial x} \left[D_I(x, y, z, T) \frac{\partial I(x, y, z, t)}{\partial x} \right] + \frac{\partial}{\partial y} \left[D_I(x, y, z, T) \frac{\partial I(x, y, z, t)}{\partial y} \right] +$$

$$\begin{aligned}
 & + \frac{\partial}{\partial z} \left[D_I(x, y, z, T) \frac{\partial I(x, y, z, t)}{\partial z} \right] - k_{I,V}(x, y, z, T) I(x, y, z, t) V(x, y, z, t) - \\
 & - k_{I,I}(x, y, z, T) I^2(x, y, z, t)
 \end{aligned} \tag{4}$$

$$\begin{aligned}
 \frac{\partial V(x, y, z, t)}{\partial t} & = \frac{\partial}{\partial x} \left[D_V(x, y, z, T) \frac{\partial V(x, y, z, t)}{\partial x} \right] + \frac{\partial}{\partial y} \left[D_V(x, y, z, T) \frac{\partial V(x, y, z, t)}{\partial y} \right] + \\
 & + \frac{\partial}{\partial z} \left[D_V(x, y, z, T) \frac{\partial V(x, y, z, t)}{\partial z} \right] - k_{I,V}(x, y, z, T) I(x, y, z, t) V(x, y, z, t) + \\
 & + k_{V,V}(x, y, z, T) V^2(x, y, z, t).
 \end{aligned}$$

Boundary and initial conditions for these equations are

$$\begin{aligned}
 \left. \frac{\partial \rho(x, y, z, t)}{\partial x} \right|_{x=0} & = 0, \quad \left. \frac{\partial \rho(x, y, z, t)}{\partial x} \right|_{x=L_x} = 0, \quad \left. \frac{\partial \rho(x, y, z, t)}{\partial y} \right|_{y=0} = 0, \quad \left. \frac{\partial \rho(x, y, z, t)}{\partial y} \right|_{y=L_y} = 0, \\
 \left. \frac{\partial \rho(x, y, z, t)}{\partial z} \right|_{z=0} & = 0, \quad \left. \frac{\partial \rho(x, y, z, t)}{\partial z} \right|_{z=L_z} = 0, \quad \rho(x, y, z, 0) = f_\rho(x, y, z).
 \end{aligned} \tag{5}$$

Here $\rho = I, V$. The function $I(x, y, z, t)$ describes the spatiotemporal distribution of concentration of radiation interstitials; $D_\rho(x, y, z, T)$ is the diffusion coefficients of point radiation defects; terms $V^2(x, y, z, t)$ and $I^2(x, y, z, t)$ correspond to generation divacancies and diinterstitials; $k_{I,V}(x, y, z, T)$ is the parameter of recombination of point radiation defects; $k_{I,I}(x, y, z, T)$ and $k_{V,V}(x, y, z, T)$ are the parameters of generation of simplest complexes of point radiation defects.

Further, we determine distributions in space and time of concentrations of divacancies $\Phi_V(x, y, z, t)$ and diinterstitials $\Phi_I(x, y, z, t)$ by solving the following system of equations.^[21,22]

$$\begin{aligned}
 \frac{\partial \Phi_I(x, y, z, t)}{\partial t} & = \frac{\partial}{\partial x} \left[D_{\Phi_I}(x, y, z, T) \frac{\partial \Phi_I(x, y, z, t)}{\partial x} \right] + \frac{\partial}{\partial y} \left[D_{\Phi_I}(x, y, z, T) \frac{\partial \Phi_I(x, y, z, t)}{\partial y} \right] + \\
 & + \frac{\partial}{\partial z} \left[D_{\Phi_I}(x, y, z, T) \frac{\partial \Phi_I(x, y, z, t)}{\partial z} \right] + k_{I,I}(x, y, z, T) I^2(x, y, z, t) - k_I(x, y, z, T) I(x, y, z, t)
 \end{aligned} \tag{6}$$

$$\begin{aligned}
 \frac{\partial \Phi_V(x, y, z, t)}{\partial t} & = \frac{\partial}{\partial x} \left[D_{\Phi_V}(x, y, z, T) \frac{\partial \Phi_V(x, y, z, t)}{\partial x} \right] + \frac{\partial}{\partial y} \left[D_{\Phi_V}(x, y, z, T) \frac{\partial \Phi_V(x, y, z, t)}{\partial y} \right] + \\
 & + \frac{\partial}{\partial z} \left[D_{\Phi_V}(x, y, z, T) \frac{\partial \Phi_V(x, y, z, t)}{\partial z} \right] + k_{V,V}(x, y, z, T) V^2(x, y, z, t) - k_V(x, y, z, T) V(x, y, z, t).
 \end{aligned}$$

Boundary and initial conditions for these equations are

$$\begin{aligned}
 \left. \frac{\partial \Phi_\rho(x, y, z, t)}{\partial x} \right|_{x=0} & = 0, \quad \left. \frac{\partial \Phi_\rho(x, y, z, t)}{\partial x} \right|_{x=L_x} = 0, \quad \left. \frac{\partial \Phi_\rho(x, y, z, t)}{\partial y} \right|_{y=0} = 0, \quad \left. \frac{\partial \Phi_\rho(x, y, z, t)}{\partial y} \right|_{y=L_y} = 0, \\
 \left. \frac{\partial \Phi_\rho(x, y, z, t)}{\partial z} \right|_{z=0} & = 0, \quad \left. \frac{\partial \Phi_\rho(x, y, z, t)}{\partial z} \right|_{z=L_z} = 0,
 \end{aligned}$$

$$\Phi_I(x, y, z, 0) = f_{\Phi_I}(x, y, z), \quad \Phi_V(x, y, z, 0) = f_{\Phi_V}(x, y, z). \tag{7}$$

Here, $D_{\phi\rho}(x,y,z,T)$ is the diffusion coefficients of the above complexes of radiation defects; $k_I(x,y,z,T)$ and $k_V(x,y,z,T)$ are the parameters of decay of these complexes.

We calculate distributions of concentrations of point radiation defects in space and time by recently elaborated approach.^[18] The approach based on transformation of approximations of diffusion coefficients in the following form: $D_{\rho}(x,y,z,T)=D_{0\rho}[1+\varepsilon_{\rho}g_{\rho}(x,y,z,T)]$, where $D_{0\rho}$ is the average values of diffusion coefficients, $0\leq\varepsilon_{\rho}<1$, $|g_{\rho}(x,y,z,T)|\leq 1$, $\rho =I,V$. We also used analogous transformation of approximations of parameters of recombination of point defects and parameters of generation of their complexes: $k_{I,V}(x,y,z,T)=k_{0I,V}[1+\varepsilon_{I,V}g_{I,V}(x,y,z,T)]$, $k_{I,I}(x,y,z,T)=k_{0I,I}[1+\varepsilon_{I,I}g_{I,I}(x,y,z,T)]$ and $k_{V,V}(x,y,z,T)=k_{0V,V}[1+\varepsilon_{V,V}g_{V,V}(x,y,z,T)]$, where $k_{0\rho 1,\rho 2}$ is the their average values, $0\leq\varepsilon_{I,V}<1$, $0\leq\varepsilon_{I,I}<1$, $0\leq\varepsilon_{V,V}<1$, $|g_{I,V}(x,y,z,T)|\leq 1$, $|g_{I,I}(x,y,z,T)|\leq 1$, $|g_{V,V}(x,y,z,T)|\leq 1$. Let us introduce the following dimensionless variables:

$$\tilde{I}(x,y,z,t) = I(x,y,z,t)/I^*, \quad \tilde{V}(x,y,z,t) = V(x,y,z,t)/V^*, \quad \omega = L^2k_{0I,V}/\sqrt{D_{0I}D_{0V}},$$

$\Omega_{\rho} = L^2k_{0\rho,\rho}/\sqrt{D_{0I}D_{0V}}$, $\vartheta = \sqrt{D_{0I}D_{0V}}t/L^2$, $\chi = x/L_x$, $\eta = y/L_y$, $\varphi = z/L_z$. The introduction leads to transformation of Equation (4) and conditions (5) to the following form

$$\begin{aligned} \frac{\partial \tilde{I}(\chi,\eta,\varphi,\vartheta)}{\partial \vartheta} &= \frac{D_{0I}}{\sqrt{D_{0I}D_{0V}}} \frac{\partial}{\partial \chi} \left\{ [1+\varepsilon_I g_I(\chi,\eta,\varphi,T)] \frac{\partial \tilde{I}(\chi,\eta,\varphi,\vartheta)}{\partial \chi} \right\} + \frac{\partial}{\partial \eta} \left\{ [1+\varepsilon_I g_I(\chi,\eta,\varphi,T)] \right. \\ &\times \left. \frac{\partial \tilde{I}(\chi,\eta,\varphi,\vartheta)}{\partial \eta} \right\} \frac{D_{0I}}{\sqrt{D_{0I}D_{0V}}} + \frac{D_{0I}}{\sqrt{D_{0I}D_{0V}}} \frac{\partial}{\partial \varphi} \left\{ [1+\varepsilon_I g_I(\chi,\eta,\varphi,T)] \frac{\partial \tilde{I}(\chi,\eta,\varphi,\vartheta)}{\partial \varphi} \right\} - \tilde{I}(\chi,\eta,\varphi,\vartheta) \times \\ &\times \omega [1+\varepsilon_{I,V} g_{I,V}(\chi,\eta,\varphi,T)] \tilde{V}(\chi,\eta,\varphi,\vartheta) - \Omega_I [1+\varepsilon_{I,I} g_{I,I}(\chi,\eta,\varphi,T)] \tilde{I}^2(\chi,\eta,\varphi,\vartheta) \end{aligned} \quad (8)$$

$$\begin{aligned} \frac{\partial \tilde{V}(\chi,\eta,\varphi,\vartheta)}{\partial \vartheta} &= \frac{D_{0V}}{\sqrt{D_{0I}D_{0V}}} \frac{\partial}{\partial \chi} \left\{ [1+\varepsilon_V g_V(\chi,\eta,\varphi,T)] \frac{\partial \tilde{V}(\chi,\eta,\varphi,\vartheta)}{\partial \chi} \right\} + \frac{\partial}{\partial \eta} \left\{ [1+\varepsilon_V g_V(\chi,\eta,\varphi,T)] \right. \\ &\times \left. \frac{\partial \tilde{V}(\chi,\eta,\varphi,\vartheta)}{\partial \eta} \right\} \frac{D_{0V}}{\sqrt{D_{0I}D_{0V}}} + \frac{D_{0V}}{\sqrt{D_{0I}D_{0V}}} \frac{\partial}{\partial \varphi} \left\{ [1+\varepsilon_V g_V(\chi,\eta,\varphi,T)] \frac{\partial \tilde{V}(\chi,\eta,\varphi,\vartheta)}{\partial \varphi} \right\} - \tilde{I}(\chi,\eta,\varphi,\vartheta) \times \\ &\times \omega [1+\varepsilon_{I,V} g_{I,V}(\chi,\eta,\varphi,T)] \tilde{V}(\chi,\eta,\varphi,\vartheta) - \Omega_V [1+\varepsilon_{V,V} g_{V,V}(\chi,\eta,\varphi,T)] \tilde{V}^2(\chi,\eta,\varphi,\vartheta) \end{aligned}$$

$$\begin{aligned} \left. \frac{\partial \tilde{\rho}(\chi,\eta,\varphi,\vartheta)}{\partial \chi} \right|_{\chi=0} &= 0, \quad \left. \frac{\partial \tilde{\rho}(\chi,\eta,\varphi,\vartheta)}{\partial \chi} \right|_{\chi=1} = 0, \quad \left. \frac{\partial \tilde{\rho}(\chi,\eta,\varphi,\vartheta)}{\partial \eta} \right|_{\eta=0} = 0, \quad \left. \frac{\partial \tilde{\rho}(\chi,\eta,\varphi,\vartheta)}{\partial \eta} \right|_{\eta=1} = 0, \\ \left. \frac{\partial \tilde{\rho}(\chi,\eta,\varphi,\vartheta)}{\partial \varphi} \right|_{\varphi=0} &= 0, \quad \left. \frac{\partial \tilde{\rho}(\chi,\eta,\varphi,\vartheta)}{\partial \varphi} \right|_{\varphi=1} = 0, \quad \tilde{\rho}(\chi,\eta,\varphi,\vartheta) = \frac{f_{\rho}(\chi,\eta,\varphi,\vartheta)}{\rho^*} \end{aligned} \quad (9)$$

We determine solutions of Equation (8) with conditions (9) framework recently introduced approach,^[18] that is, as the power series

$$\tilde{\rho}(\chi,\eta,\varphi,\vartheta) = \sum_{i=0}^{\infty} \varepsilon_{\rho}^i \sum_{j=0}^{\infty} \omega^j \sum_{k=0}^{\infty} \Omega_{\rho}^k \tilde{\rho}_{ijk}(\chi,\eta,\varphi,\vartheta). \quad (10)$$

Substitution of the series (10) into Equation (8) and conditions (9) gives us possibility to obtain equations for initial order approximations of concentration of point defects $\tilde{I}_{000}(\chi,\eta,\varphi,\vartheta)$ and $\tilde{V}_{000}(\chi,\eta,\varphi,\vartheta)$ and corrections for them $\tilde{I}_{ijk}(\chi,\eta,\varphi,\vartheta)$ and $\tilde{V}_{ijk}(\chi,\eta,\varphi,\vartheta)$, $i \geq 1, j \geq 1, k \geq 1$. The equations are presented in the Appendix. Solutions of the equations could be obtained by standard Fourier approach.^[24,25] The solutions are presented in the Appendix.

Now, we calculate distributions of concentrations of simplest complexes of point radiation defects in space and time. To determine the distributions, we transform approximations of diffusion coefficients in the following form: $D_{\phi\rho}(x,y,z,T)=D_{0\phi\rho}[1+\varepsilon_{\phi\rho}g_{\phi\rho}(x,y,z,T)]$, where $D_{0\phi\rho}$ is the average values of diffusion coefficients. In this situation, the Equation (6) could be written as

$$\begin{aligned} \frac{\partial \Phi_I(x,y,z,t)}{\partial t} &= D_{0\phi I} \frac{\partial}{\partial x} \left\{ [1+\varepsilon_{\phi I}g_{\phi I}(x,y,z,T)] \frac{\partial \Phi_I(x,y,z,t)}{\partial x} \right\} + k_{I,I}(x,y,z,T) I^2(x,y,z,t) + \\ &+ D_{0\phi I} \frac{\partial}{\partial y} \left\{ [1+\varepsilon_{\phi I}g_{\phi I}(x,y,z,T)] \frac{\partial \Phi_I(x,y,z,t)}{\partial y} \right\} + D_{0\phi I} \frac{\partial}{\partial z} \left\{ [1+\varepsilon_{\phi I}g_{\phi I}(x,y,z,T)] \frac{\partial \Phi_I(x,y,z,t)}{\partial z} \right\} - \\ &- k_I(x,y,z,T) I(x,y,z,t) \\ \frac{\partial \Phi_V(x,y,z,t)}{\partial t} &= D_{0\phi V} \frac{\partial}{\partial x} \left\{ [1+\varepsilon_{\phi V}g_{\phi V}(x,y,z,T)] \frac{\partial \Phi_V(x,y,z,t)}{\partial x} \right\} + k_{I,I}(x,y,z,T) I^2(x,y,z,t) + \\ &+ D_{0\phi V} \frac{\partial}{\partial y} \left\{ [1+\varepsilon_{\phi V}g_{\phi V}(x,y,z,T)] \frac{\partial \Phi_V(x,y,z,t)}{\partial y} \right\} + D_{0\phi V} \frac{\partial}{\partial z} \left\{ [1+\varepsilon_{\phi V}g_{\phi V}(x,y,z,T)] \frac{\partial \Phi_V(x,y,z,t)}{\partial z} \right\} - \\ &- k_I(x,y,z,T) I(x,y,z,t). \end{aligned}$$

Farther, we determine solutions of above equations as the following power series

$$\Phi_{\rho}(x,y,z,t) = \sum_{i=0}^{\infty} \varepsilon_{\phi\rho}^i \Phi_{\rho i}(x,y,z,t). \tag{11}$$

Now, we used the series (11) into Equation (6) and appropriate boundary and initial conditions. The using gives the possibility to obtain equations for initial order approximations of concentrations of complexes of defects $\Phi_{\rho 0}(x,y,z,t)$, corrections for them $\Phi_{\rho i}(x,y,z,t)$ (for them $i \geq 1$) and boundary and initial conditions for them. We remove equations and conditions to the Appendix. Solutions of the equations have been calculated by standard approaches^[24,25] and presented in the Appendix.

Now, we calculate distribution of concentration of dopant in space and time using the approach, which was used for analysis of radiation defects. To use the approach, we consider following transformation of approximation of dopant diffusion coefficient: $D_L(x,y,z,T)=D_{0L}[1+\varepsilon_L g_L(x,y,z,T)]$, where D_{0L} is the average value of dopant diffusion coefficient, $0 \leq \varepsilon_L < 1$, $|g_L(x,y,z,T)| \leq 1$. Farther, we consider solution of Equation (1) as the following series:

$$C(x,y,z,t) = \sum_{i=0}^{\infty} \varepsilon_L^i \sum_{j=1}^{\infty} \xi^j C_{ij}(x,y,z,t).$$

Using the relation into Equation (1) and conditions (2) leads to obtaining equations for the functions $C_{ij}(x,y,z,t)$ ($i \geq 1, j \geq 1$), boundary and initial conditions for them. The equations are presented in the Appendix. Solutions of the equations have been calculated by standard approaches (see, for example,^[24,25]). The solutions are presented in the Appendix.

We analyzed distributions of concentrations of dopant and radiation defects in space and time analytically using the second-order approximations on all parameters, which have been used in appropriate series. Usually, the second-order approximations are enough good approximations to make qualitative analysis and to obtain quantitative results. All analytical results have been checked by numerical simulation.

DISCUSSION

In this section, we analyzed spatiotemporal distributions of concentrations of dopants. Figure 2 shows typical spatial distributions of concentrations of dopants in neighborhood of interfaces of heterostructures. We calculate these distributions of concentrations of dopants under the following condition: Value of dopant diffusion coefficient in doped area is larger, than value of dopant diffusion coefficient in nearest areas. In this situation, one can find increasing of compactness of field-effect transistors with increasing of homogeneity of distribution of concentration of dopant at 1 time. Changing relation between values of dopant diffusion coefficients leads to opposite result [Figure 3].

It should be noted that framework the considered approach one shall optimize annealing of dopant and/or radiation defects. To do the optimization, we used recently introduced criterion.^[26-33] The optimization based on approximation real distribution by step-wise function $\psi(x,y,z)$ [Figure 4]. Farther, the required values of optimal annealing time have been calculated by minimization the following mean-squared error.

$$U = \frac{1}{L_x L_y L_z} \int_0^{L_x} \int_0^{L_y} \int_0^{L_z} [C(x,y,z, \Theta) - \psi(x,y,z)] dz dy dx. \tag{12}$$

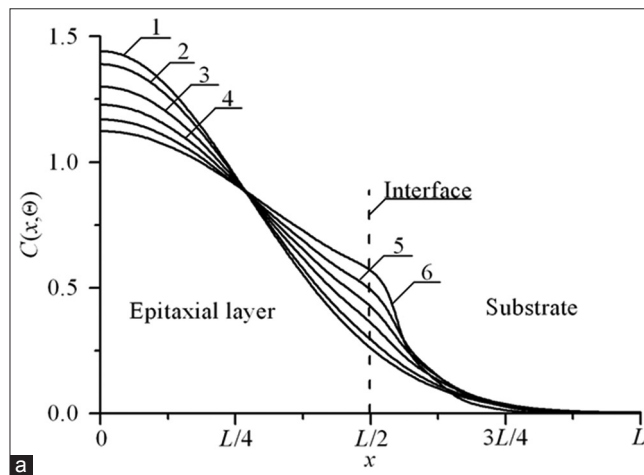

Figure 2: (a) Dependences of concentration of dopant, infused in heterostructure from Figure 1, on coordinate in direction, which is perpendicular to interface between epitaxial layer substrate. Difference between values of dopant diffusion coefficient in layers of heterostructure increases with increasing of number of curves. Value of dopant diffusion coefficient in the epitaxial layer is larger, than value of dopant diffusion coefficient in the substrate

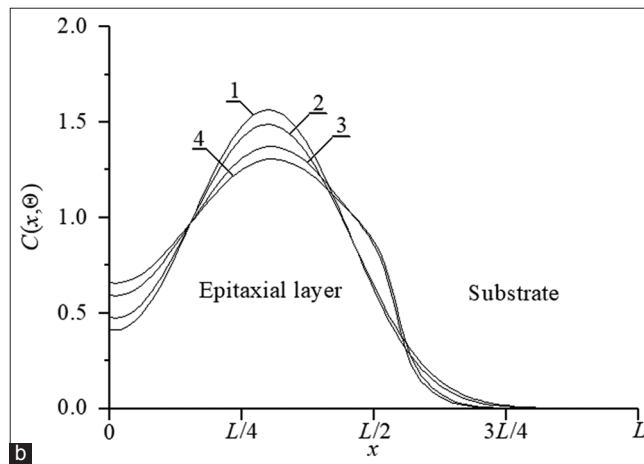

Figure 2: (b) Dependences of concentration of dopant, implanted in heterostructure from Figure 1, on coordinate in direction, which is perpendicular to interface between epitaxial layer substrate. Difference between values of dopant diffusion coefficient in layers of heterostructure increases with increasing of number of curves. Value of dopant diffusion coefficient in the epitaxial layer is larger, than value of dopant diffusion coefficient in the substrate. Curve 1 corresponds to homogenous sample and annealing time $\Theta = 0.0048 (L_x^2 + L_y^2 + L_z^2)/D_0$. Curve 2 corresponds to homogenous sample and annealing time $\Theta = 0.0057 (L_x^2 + L_y^2 + L_z^2)/D_0$. Curves 3 and 4 correspond to heterostructure from Figure 1; annealing times $\Theta = 0.0048 (L_x^2 + L_y^2 + L_z^2)/D_0$ and $\Theta = 0.0057 (L_x^2 + L_y^2 + L_z^2)/D_0$, respectively

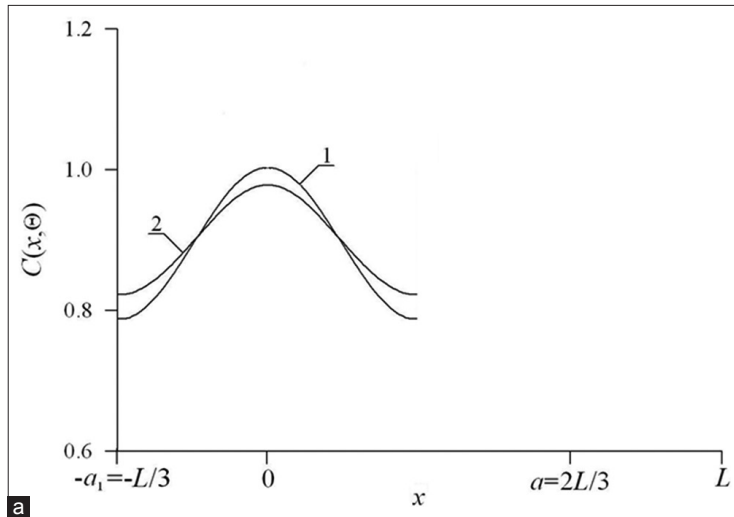

Figure 3: (a) Distributions of concentration of dopant, infused in average section of epitaxial layer of heterostructure from Figure 1 in direction parallel to interface between epitaxial layer and substrate of heterostructure. Difference between values of dopant diffusion coefficients increases with increasing of number of curves. Value of dopant diffusion coefficient in this section is smaller, than value of dopant diffusion coefficient in nearest sections

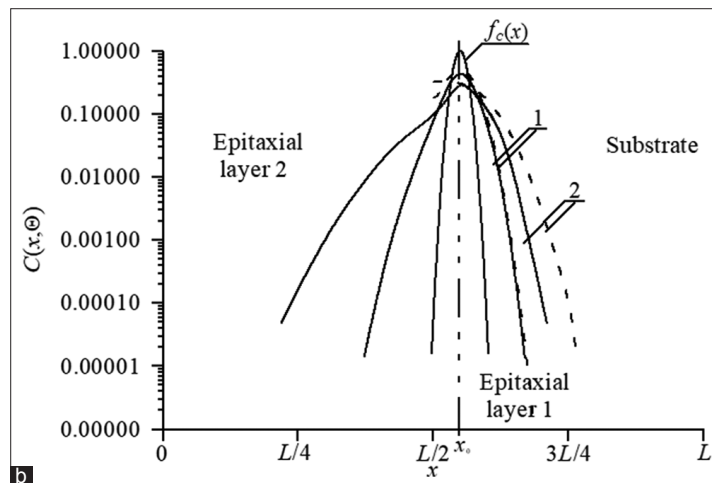

Figure 3: (b) Calculated distributions of implanted dopant in epitaxial layers of heterostructure. Solid lines are spatial distributions of implanted dopant in system of two epitaxial layers. Dashed lines are spatial distributions of implanted dopant in one epitaxial layer. Annealing time increases with increasing of number of curves

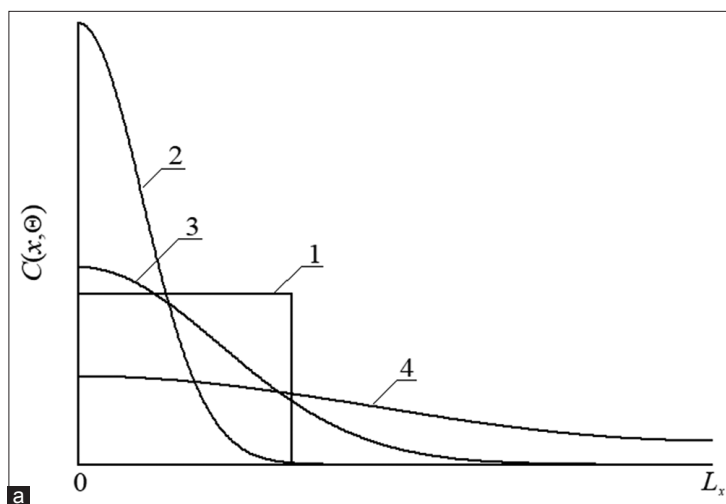

Figure 4: (a) Distributions of concentration of infused dopant in depth of heterostructure from Figure 1 for different values of annealing time (curves 2-4) and idealized step-wise approximation (curve 1). Increasing of number of curve corresponds to increasing of annealing time

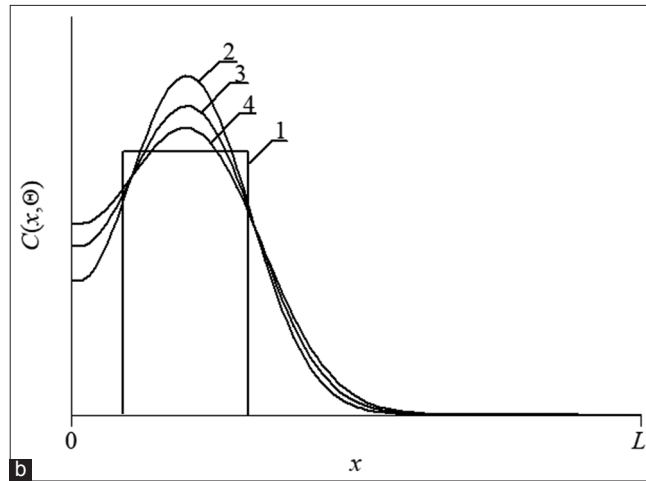

Figure 4: (b) Distributions of concentration of implanted dopant in depth of heterostructure from Figure 1 for different values of annealing time (curves 2-4) and idealized step-wise approximation (curve 1). Increasing of number of curve corresponds to increasing of annealing time

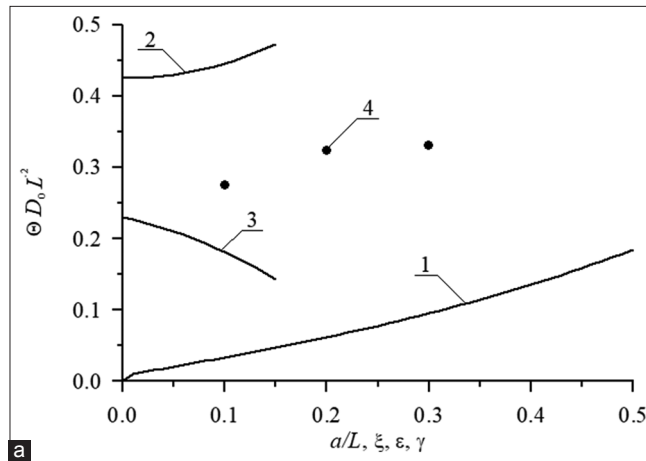

Figure 5: (a) Dimensionless optimal annealing time of infused dopant as a function of several parameters. Curve 1 describes the dependence of the annealing time on the relation a/L and $\zeta = \gamma = 0$ for equal to each other values of dopant diffusion coefficient in all parts of heterostructure. Curve 2 describes the dependence of the annealing time on value of parameter ϵ for $a/L=1/2$ and $\zeta = \gamma = 0$. Curve 3 describes the dependence of the annealing time on value of parameter ζ for $a/L=1/2$ and $\epsilon = \gamma = 0$. Curve 4 describes the dependence of the annealing time on value of parameter γ for $a/L=1/2$ and $\epsilon = \zeta = 0$

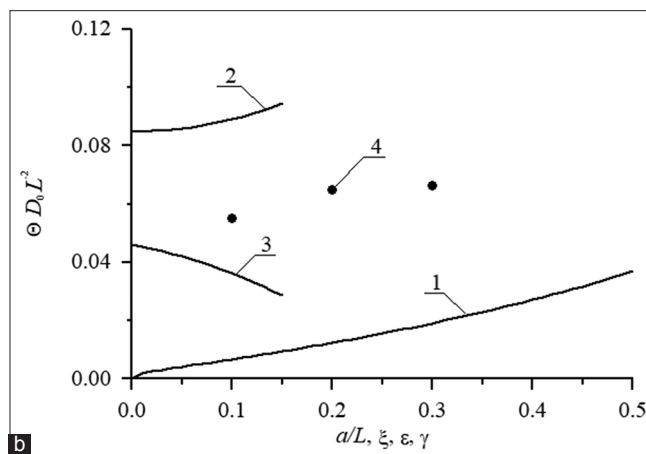

Figure 5: (b) Dimensionless optimal annealing time of implanted dopant as a function of several parameters. Curve 1 describes the dependence of the annealing time on the relation a/L and $\zeta = \gamma = 0$ for equal to each other values of dopant diffusion coefficient in all parts of heterostructure. Curve 2 describes the dependence of the annealing time on value of parameter ϵ for $a/L=1/2$ and $\zeta = \gamma = 0$. Curve 3 describes the dependence of the annealing time on value of parameter ζ for $a/L=1/2$ and $\epsilon = \gamma = 0$. Curve 4 describes the dependence of the annealing time on value of parameter γ for $a/L=1/2$ and $\epsilon = \zeta = 0$

We show optimal values of annealing time as functions of parameters on Figure 5. It is known that standard step of manufactured ion-doped structures is annealing of radiation defects. In the ideal case after finishing the annealing, dopant achieves interface between layers of heterostructure. If the dopant has no enough time to achieve the interface, it is practicably to anneal the dopant additionally. Figure 5b shows the described dependences of optimal values of additional annealing time for the same parameters as for Figure 5a. Necessity to anneal radiation defects leads to smaller values of optimal annealing of implanted dopant in comparison with optimal annealing time of infused dopant.^[19-23]

CONCLUSIONS

In this paper, we introduce an approach to increase integration rate of element of a switched-capacitor step-down DC–DC converter. The approach gives us possibility to decrease area of the elements with smaller increasing of the element's thickness.

REFERENCES

1. Lachin VI, Savelov NS. Electronics. Phoenix: Rostov-na-Donu; 2001.
2. Alexenko AG, Shagurin II. Microcircuitry. Moscow: Radio and Communication; 1990.
3. Avaev NA, Naumov YE, Frolkin VT. Basis of Microelectronics. Moscow: Radio and Communication; 1991.
4. Ghiasi RR, Sahafi A, Geshlaghi JS, Kouzekanani ZD. A 2: 1 switched-capacitor DC-DC converter for low power circuits. *Analog Integr Circ Sig Process* 2015;84:215-22.
5. Fathi D, Forouzandeh B, Masoumi N. New enhanced noise analysis in active mixers in nanoscale technologies. *Nano* 2009;4:233-8.
6. Chachuli SA, Fasyar PN, Soin N, Kar NM, Yusop N. On approach to increase integration rate of elements. *Mat Sci Sem Proc* 2014;24:9-14.
7. Ageev AO, Belyaev AE, Boltovets NS, Ivanov VN, Konakova RV, Kudryk YY, et al. Technologies dependencies. *Semiconductors* 2009;43:897-903.
8. Li Z, Waldron J, Detchprohm T, Wetzel C, Karlicek RF Jr., Chow TP. Monolithic integration of light-emitting diodes and power metal-oxide-semiconductor channel high-electron-mobility transistors for light-emitting power integrated circuits in GaN on sapphire substrate. *Appl Phys Lett* 2013;102:192107-9.
9. Tsai JH, Chiu SY, Lour WS, Guo DF. High-performance InGaP/GaAs pnp δ -doped heterojunction bipolar transistor. *Semiconductors* 2009;43:971-4.
10. Alexandrov OV, Zakhar'in AO, Sobolev NA, Shek EI, Makoviychuk MM, Parshin EO. Formation of donor centers upon annealing of dysprosium-and holmiumimplanted silicon. *Semiconductors* 1998;32:1029-32.
11. Kumar MJ, Singh TV. Quantum confinement effects in strained silicon mosfets. *Int J Nanosci* 2008;7:81-4.
12. Sinsersuksakul P, Hartman K, Kim SB, Heo J, Sun L, Park HH, et al. Band alignment of SnS/Zn (O, S) heterojunctions in SnS thin film solar cells. *Appl Phys Lett* 2013;102:53901-5.
13. Reynolds JG, Reynolds CL, Mohanta A Jr., Muth JF, Rowe JE, Everitt HO, et al. Shallow acceptor complexes in p-type ZnO. *Appl Phys Lett* 2013;102:152114-8.
14. Ong KK, Pey KL, Lee PS, Wee AT, Wang XC, Chong YF. Dopant distribution in the recrystallization transient at the maximum melt depth induced by laser annealing. *Appl Phys Lett* 2006;89:172111-4.
15. Wang HT, Tan LS, Chor EF. Pulsed laser annealing of Be-implanted GaN. *J Appl Phys* 2006;98:94901-5.
16. Shishiyanu ST, Shishiyanu TS, Railyan SK. Shallow pn-junctions in Si prepared by pulse photon annealing. *Semiconductors* 2002;36:611-7.
17. Bykov YV, Yermeev AG, Zharova NA, Plotnikov IV, Rybakov KI, Drozdov MN, et al. Diffusion processes in semiconductor structures during microwave annealing. *Radiophys Quant Electron* 2003;43:836-43.
18. Pankratov EL, Bulaeva EA. Doping of materials during manufacture p-n-junctions and bipolar transistors. Analytical approaches to model technological approaches and ways of optimization of distributions of dopants. *Rev Theor Sci* 2013;1:58-82.
19. Erofeev YN. Pulse Devices. Moscow: Higher School; 1989.
20. Kozlivsky VV. Modification of Semiconductors by Proton Beams. Sant-Peterburg: Nauka; 2003.
21. Gotra ZY. Technology of Microelectronic Devices. Moscow: Radio and Communication; 1991.
22. Vinetskiy VL, Kholodar GA. Radiative Physics of Semiconductors. Kiev: Naukova Dumka; 1979.
23. Fahey PM, Griffin PB, Plummer JD. Point defects and dopant diffusion in silicon. *Rev Mod Phys* 1989;61:289-388.
24. Tikhonov AN, Samarskii AA. The Mathematical Physics Equations. Moscow: Nauka; 1972.
25. Carslaw HS, Jaeger JC. Conduction of Heat in Solids. Oxford: Oxford University Press; 1964.
26. Pankratov EL. Dopant diffusion dynamics and optimal diffusion time as influenced by diffusion-coefficient nonuniformity. *Russ Micro Electron* 2007;36:33-9.

27. Pankratov EL. Redistribution of a dopant during annealing of radiation defects in a multilayer structure by laser scans for production of an implanted-junction rectifier. *Int J Nanosci* 2008;7:187-97.
28. Pankratov EL. On approach to optimize manufacturing of bipolar heterotransistors framework circuit of an operational amplifier to increase their integration rate. Influence mismatch-induced stress. *J Comput Theor Nanosci* 2017;14:4885-99.
29. Pankratov EL. On optimization of manufacturing of two-phase logic circuit based on heterostructures to increase density of their elements. Influence of miss-match induced stress. *Adv Sci Eng Med* 2017;9:787-801.
30. Pankratov EL, Bulaeva EA. On increasing of density of transistors in a hybrid cascaded multilevel inverter. *Multidiscip Mod Mater Struct* 2017;13:664-77.
31. Pankratov EL, Bulaeva EA. An approach to manufacture a heterobipolar transistors in thin film structures. On the method of optimization. *Int J Micro Nano Scale Trans* 2014;4:17-31.
32. Pankratov EL, Bulaeva EA. An analytical approach for analysis and optimization of formation of field-effect heterotransistors. *Multidiscip Mod Mater Struct* 2016;12:578-604.
33. Pankratov EL, Bulaeva EA. An approach to increase the integration rate of planar drift heterobipolar transistors. *Mater Sci Semicond Proc* 2015;34:260-8.

APPENDIX

Equations for the functions $\tilde{I}_{ijk}(\chi, \eta, \varphi, \vartheta)$ and $\tilde{V}_{ijk}(\chi, \eta, \varphi, \vartheta)$, $i \geq 0, j \geq 0, k \geq 0$ and conditions for them

$$\frac{\partial \tilde{I}_{000}(\chi, \eta, \varphi, \vartheta)}{\partial \vartheta} = \sqrt{\frac{D_{0I}}{D_{0V}}} \left[\frac{\partial^2 \tilde{I}_{000}(\chi, \eta, \varphi, \vartheta)}{\partial \chi^2} + \frac{\partial^2 \tilde{I}_{000}(\chi, \eta, \varphi, \vartheta)}{\partial \eta^2} + \frac{\partial^2 \tilde{I}_{000}(\chi, \eta, \varphi, \vartheta)}{\partial \varphi^2} \right]$$

$$\frac{\partial \tilde{V}_{000}(\chi, \eta, \varphi, \vartheta)}{\partial \vartheta} = \sqrt{\frac{D_{0V}}{D_{0I}}} \left[\frac{\partial^2 \tilde{V}_{000}(\chi, \eta, \varphi, \vartheta)}{\partial \chi^2} + \frac{\partial^2 \tilde{V}_{000}(\chi, \eta, \varphi, \vartheta)}{\partial \eta^2} + \frac{\partial^2 \tilde{V}_{000}(\chi, \eta, \varphi, \vartheta)}{\partial \varphi^2} \right],$$

$$\frac{\partial \tilde{I}_{i00}(\chi, \vartheta)}{\partial \vartheta} = \sqrt{\frac{D_{0I}}{D_{0V}}} \left[\frac{\partial^2 \tilde{I}_{i00}(\chi, \eta, \varphi, \vartheta)}{\partial \chi^2} + \frac{\partial^2 \tilde{I}_{i00}(\chi, \eta, \varphi, \vartheta)}{\partial \eta^2} + \frac{\partial^2 \tilde{I}_{i00}(\chi, \eta, \varphi, \vartheta)}{\partial \varphi^2} \right] + \sqrt{\frac{D_{0I}}{D_{0V}}} \times$$

$$\times \left\{ \frac{\partial}{\partial \chi} \left[g_I(\chi, \eta, \varphi, T) \frac{\partial \tilde{I}_{i-100}(\chi, \eta, \varphi, \vartheta)}{\partial \chi} \right] + \frac{\partial}{\partial \eta} \left[g_I(\chi, \eta, \varphi, T) \frac{\partial \tilde{I}_{i-100}(\chi, \eta, \varphi, \vartheta)}{\partial \eta} \right] + \right.$$

$$\left. + \frac{\partial}{\partial \varphi} \left[g_I(\chi, \eta, \varphi, T) \frac{\partial \tilde{I}_{i-100}(\chi, \eta, \varphi, \vartheta)}{\partial \varphi} \right] \right\}, i \geq 1,$$

$$\frac{\partial \tilde{V}_{i00}(\chi, \vartheta)}{\partial \vartheta} = \sqrt{\frac{D_{0V}}{D_{0I}}} \left[\frac{\partial^2 \tilde{V}_{i00}(\chi, \eta, \varphi, \vartheta)}{\partial \chi^2} + \frac{\partial^2 \tilde{V}_{i00}(\chi, \eta, \varphi, \vartheta)}{\partial \eta^2} + \frac{\partial^2 \tilde{V}_{i00}(\chi, \eta, \varphi, \vartheta)}{\partial \varphi^2} \right] + \frac{\partial}{\partial \chi} \left[g_V(\chi, \eta, \varphi, T) \times \right.$$

$$\times \frac{\partial \tilde{V}_{i-100}(\chi, \eta, \varphi, \vartheta)}{\partial \chi} \left. \right] \sqrt{\frac{D_{0V}}{D_{0I}}} + \sqrt{\frac{D_{0V}}{D_{0I}}} \frac{\partial}{\partial \eta} \left[g_V(\chi, \eta, \varphi, T) \frac{\partial \tilde{V}_{i-100}(\chi, \eta, \varphi, \vartheta)}{\partial \eta} \right] + \frac{\partial}{\partial \varphi} \left[g_V(\chi, \eta, \varphi, T) \times \right.$$

$$\times \frac{\partial \tilde{V}_{i-100}(\chi, \eta, \varphi, \vartheta)}{\partial \varphi} \left. \right] \sqrt{\frac{D_{0V}}{D_{0I}}}, i \geq 1,$$

$$\frac{\partial \tilde{I}_{010}(\chi, \eta, \varphi, \vartheta)}{\partial \vartheta} = \sqrt{\frac{D_{0I}}{D_{0V}}} \left[\frac{\partial^2 \tilde{I}_{010}(\chi, \eta, \varphi, \vartheta)}{\partial \chi^2} + \frac{\partial^2 \tilde{I}_{010}(\chi, \eta, \varphi, \vartheta)}{\partial \eta^2} + \frac{\partial^2 \tilde{I}_{010}(\chi, \eta, \varphi, \vartheta)}{\partial \varphi^2} \right] -$$

$$- [1 + \varepsilon_{I,V} g_{I,V}(\chi, \eta, \varphi, T)] \tilde{I}_{000}(\chi, \eta, \varphi, \vartheta) \tilde{V}_{000}(\chi, \eta, \varphi, \vartheta)$$

$$\frac{\partial \tilde{V}_{010}(\chi, \eta, \varphi, \vartheta)}{\partial \vartheta} = \sqrt{\frac{D_{0V}}{D_{0I}}} \left[\frac{\partial^2 \tilde{V}_{010}(\chi, \eta, \varphi, \vartheta)}{\partial \chi^2} + \frac{\partial^2 \tilde{V}_{010}(\chi, \eta, \varphi, \vartheta)}{\partial \eta^2} + \frac{\partial^2 \tilde{V}_{010}(\chi, \eta, \varphi, \vartheta)}{\partial \varphi^2} \right] -$$

$$- [1 + \varepsilon_{I,V} g_{I,V}(\chi, \eta, \varphi, T)] \tilde{I}_{000}(\chi, \eta, \varphi, \vartheta) \tilde{V}_{000}(\chi, \eta, \varphi, \vartheta);$$

$$\frac{\partial \tilde{I}_{020}(\chi, \eta, \varphi, \vartheta)}{\partial \vartheta} = \sqrt{\frac{D_{0I}}{D_{0V}}} \left[\frac{\partial^2 \tilde{I}_{020}(\chi, \eta, \varphi, \vartheta)}{\partial \chi^2} + \frac{\partial^2 \tilde{I}_{020}(\chi, \eta, \varphi, \vartheta)}{\partial \eta^2} + \frac{\partial^2 \tilde{I}_{020}(\chi, \eta, \varphi, \vartheta)}{\partial \varphi^2} \right] -$$

$$- [1 + \varepsilon_{I,V} g_{I,V}(\chi, \eta, \varphi, T)] [\tilde{I}_{010}(\chi, \eta, \varphi, \vartheta) \tilde{V}_{000}(\chi, \eta, \varphi, \vartheta) + \tilde{I}_{000}(\chi, \eta, \varphi, \vartheta) \tilde{V}_{010}(\chi, \eta, \varphi, \vartheta)]$$

$$\begin{aligned} \frac{\partial \tilde{V}_{020}(\chi, \eta, \varphi, \vartheta)}{\partial \vartheta} &= \sqrt{\frac{D_{0I}}{D_{0V}}} \left[\frac{\partial^2 \tilde{V}_{020}(\chi, \eta, \varphi, \vartheta)}{\partial \chi^2} + \frac{\partial^2 \tilde{V}_{020}(\chi, \eta, \varphi, \vartheta)}{\partial \eta^2} + \frac{\partial^2 \tilde{V}_{020}(\chi, \eta, \varphi, \vartheta)}{\partial \varphi^2} \right] - \\ &- [1 + \varepsilon_{I,V} g_{I,V}(\chi, \eta, \varphi, T)] [\tilde{I}_{010}(\chi, \eta, \varphi, \vartheta) \tilde{V}_{000}(\chi, \eta, \varphi, \vartheta) + \tilde{I}_{000}(\chi, \eta, \varphi, \vartheta) \tilde{V}_{010}(\chi, \eta, \varphi, \vartheta)]; \\ \frac{\partial \tilde{I}_{001}(\chi, \eta, \varphi, \vartheta)}{\partial \vartheta} &= \sqrt{\frac{D_{0I}}{D_{0V}}} \left[\frac{\partial^2 \tilde{I}_{001}(\chi, \eta, \varphi, \vartheta)}{\partial \chi^2} + \frac{\partial^2 \tilde{I}_{001}(\chi, \eta, \varphi, \vartheta)}{\partial \eta^2} + \frac{\partial^2 \tilde{I}_{001}(\chi, \eta, \varphi, \vartheta)}{\partial \varphi^2} \right] - \\ &- [1 + \varepsilon_{I,I} g_{I,I}(\chi, \eta, \varphi, T)] \tilde{I}_{000}^2(\chi, \eta, \varphi, \vartheta) \\ \frac{\partial \tilde{V}_{001}(\chi, \eta, \varphi, \vartheta)}{\partial \vartheta} &= \sqrt{\frac{D_{0V}}{D_{0I}}} \left[\frac{\partial^2 \tilde{V}_{001}(\chi, \eta, \varphi, \vartheta)}{\partial \chi^2} + \frac{\partial^2 \tilde{V}_{001}(\chi, \eta, \varphi, \vartheta)}{\partial \eta^2} + \frac{\partial^2 \tilde{V}_{001}(\chi, \eta, \varphi, \vartheta)}{\partial \varphi^2} \right] - \\ &- [1 + \varepsilon_{I,I} g_{I,I}(\chi, \eta, \varphi, T)] \tilde{V}_{000}^2(\chi, \eta, \varphi, \vartheta); \\ \frac{\partial \tilde{I}_{110}(\chi, \eta, \varphi, \vartheta)}{\partial \vartheta} &= \sqrt{\frac{D_{0I}}{D_{0V}}} \left[\frac{\partial^2 \tilde{I}_{110}(\chi, \eta, \varphi, \vartheta)}{\partial \chi^2} + \frac{\partial^2 \tilde{I}_{110}(\chi, \eta, \varphi, \vartheta)}{\partial \eta^2} + \frac{\partial^2 \tilde{I}_{110}(\chi, \eta, \varphi, \vartheta)}{\partial \varphi^2} \right] + \sqrt{\frac{D_{0I}}{D_{0V}}} \times \\ &\times \left\{ \frac{\partial}{\partial \chi} \left[g_I(\chi, \eta, \varphi, T) \frac{\partial \tilde{I}_{010}(\chi, \eta, \varphi, \vartheta)}{\partial \chi} \right] + \frac{\partial}{\partial \eta} \left[g_I(\chi, \eta, \varphi, T) \frac{\partial \tilde{I}_{010}(\chi, \eta, \varphi, \vartheta)}{\partial \eta} \right] + \frac{\partial}{\partial \varphi} \left[g_I(\chi, \eta, \varphi, T) \times \right. \right. \\ &\times \left. \left. \frac{\partial \tilde{I}_{010}(\chi, \eta, \varphi, \vartheta)}{\partial \varphi} \right] \right\} - [\tilde{I}_{100}(\chi, \eta, \varphi, \vartheta) \tilde{V}_{000}(\chi, \eta, \varphi, \vartheta) + \tilde{I}_{000}(\chi, \eta, \varphi, \vartheta) \tilde{V}_{100}(\chi, \eta, \varphi, \vartheta)] \times \\ &\times [1 + \varepsilon_{I,I} g_{I,I}(\chi, \eta, \varphi, T)] \\ \frac{\partial \tilde{V}_{110}(\chi, \eta, \varphi, \vartheta)}{\partial \vartheta} &= \sqrt{\frac{D_{0V}}{D_{0I}}} \left[\frac{\partial^2 \tilde{V}_{110}(\chi, \eta, \varphi, \vartheta)}{\partial \chi^2} + \frac{\partial^2 \tilde{V}_{110}(\chi, \eta, \varphi, \vartheta)}{\partial \eta^2} + \frac{\partial^2 \tilde{V}_{110}(\chi, \eta, \varphi, \vartheta)}{\partial \varphi^2} \right] + \\ &+ \sqrt{\frac{D_{0V}}{D_{0I}}} \left\{ \frac{\partial}{\partial \chi} \left[g_V(\chi, \eta, \varphi, T) \frac{\partial \tilde{V}_{010}(\chi, \eta, \varphi, \vartheta)}{\partial \chi} \right] + \frac{\partial}{\partial \eta} \left[g_V(\chi, \eta, \varphi, T) \frac{\partial \tilde{V}_{010}(\chi, \eta, \varphi, \vartheta)}{\partial \eta} \right] + \right. \\ &+ \left. \frac{\partial}{\partial \varphi} \left[g_V(\chi, \eta, \varphi, T) \frac{\partial \tilde{V}_{010}(\chi, \eta, \varphi, \vartheta)}{\partial \varphi} \right] \right\} - [1 + \varepsilon_{V,V} g_{V,V}(\chi, \eta, \varphi, T)] \times \\ &\times [\tilde{V}_{100}(\chi, \eta, \varphi, \vartheta) \tilde{I}_{000}(\chi, \eta, \varphi, \vartheta) + \tilde{V}_{000}(\chi, \eta, \varphi, \vartheta) \tilde{I}_{100}(\chi, \eta, \varphi, \vartheta)]; \\ \frac{\partial \tilde{I}_{002}(\chi, \eta, \varphi, \vartheta)}{\partial \vartheta} &= \sqrt{\frac{D_{0I}}{D_{0V}}} \left[\frac{\partial^2 \tilde{I}_{002}(\chi, \eta, \varphi, \vartheta)}{\partial \chi^2} + \frac{\partial^2 \tilde{I}_{002}(\chi, \eta, \varphi, \vartheta)}{\partial \eta^2} + \frac{\partial^2 \tilde{I}_{002}(\chi, \eta, \varphi, \vartheta)}{\partial \varphi^2} \right] - \end{aligned}$$

$$\begin{aligned}
 & -[1 + \varepsilon_{I,I} g_{I,I}(\chi, \eta, \varphi, T)] \tilde{I}_{001}(\chi, \eta, \varphi, \vartheta) \tilde{I}_{000}(\chi, \eta, \varphi, \vartheta) \\
 \frac{\partial \tilde{V}_{002}(\chi, \eta, \varphi, \vartheta)}{\partial \vartheta} &= \sqrt{\frac{D_{0V}}{D_{0I}}} \left[\frac{\partial^2 \tilde{V}_{002}(\chi, \eta, \varphi, \vartheta)}{\partial \chi^2} + \frac{\partial^2 \tilde{V}_{002}(\chi, \eta, \varphi, \vartheta)}{\partial \eta^2} + \frac{\partial^2 \tilde{V}_{002}(\chi, \eta, \varphi, \vartheta)}{\partial \varphi^2} \right] - \\
 & -[1 + \varepsilon_{V,V} g_{V,V}(\chi, \eta, \varphi, E)] \tilde{V}_{001}(\chi, \eta, \varphi, \vartheta) \tilde{V}_{000}(\chi, \eta, \varphi, \vartheta); \\
 \frac{\partial \tilde{I}_{101}(\chi, \eta, \varphi, \vartheta)}{\partial \vartheta} &= \sqrt{\frac{D_{0I}}{D_{0V}}} \left[\frac{\partial^2 \tilde{I}_{101}(\chi, \eta, \varphi, \vartheta)}{\partial \chi^2} + \frac{\partial^2 \tilde{I}_{101}(\chi, \eta, \varphi, \vartheta)}{\partial \eta^2} + \frac{\partial^2 \tilde{I}_{101}(\chi, \eta, \varphi, \vartheta)}{\partial \varphi^2} \right] + \\
 & + \sqrt{\frac{D_{0I}}{D_{0V}}} \left\{ \frac{\partial}{\partial \chi} \left[g_I(\chi, \eta, \varphi, T) \frac{\partial \tilde{I}_{001}(\chi, \eta, \varphi, \vartheta)}{\partial \chi} \right] + \frac{\partial}{\partial \eta} \left[g_I(\chi, \eta, \varphi, T) \frac{\partial \tilde{I}_{001}(\chi, \eta, \varphi, \vartheta)}{\partial \eta} \right] + \right. \\
 & \left. + \frac{\partial}{\partial \varphi} \left[g_I(\chi, \eta, \varphi, T) \frac{\partial \tilde{I}_{001}(\chi, \eta, \varphi, \vartheta)}{\partial \varphi} \right] \right\} - [1 + \varepsilon_I g_I(\chi, \eta, \varphi, T)] \tilde{I}_{100}(\chi, \eta, \varphi, \vartheta) \tilde{V}_{000}(\chi, \eta, \varphi, \vartheta) \\
 \frac{\partial \tilde{V}_{101}(\chi, \eta, \varphi, \vartheta)}{\partial \vartheta} &= \sqrt{\frac{D_{0V}}{D_{0I}}} \left[\frac{\partial^2 \tilde{V}_{101}(\chi, \eta, \varphi, \vartheta)}{\partial \chi^2} + \frac{\partial^2 \tilde{V}_{101}(\chi, \eta, \varphi, \vartheta)}{\partial \eta^2} + \frac{\partial^2 \tilde{V}_{101}(\chi, \eta, \varphi, \vartheta)}{\partial \varphi^2} \right] + \\
 & + \sqrt{\frac{D_{0V}}{D_{0I}}} \left\{ \frac{\partial}{\partial \chi} \left[g_V(\chi, \eta, \varphi, T) \frac{\partial \tilde{V}_{001}(\chi, \eta, \varphi, \vartheta)}{\partial \chi} \right] + \frac{\partial}{\partial \eta} \left[g_V(\chi, \eta, \varphi, T) \frac{\partial \tilde{V}_{001}(\chi, \eta, \varphi, \vartheta)}{\partial \eta} \right] + \right. \\
 & \left. + \frac{\partial}{\partial \varphi} \left[g_V(\chi, \eta, \varphi, T) \frac{\partial \tilde{V}_{001}(\chi, \eta, \varphi, \vartheta)}{\partial \varphi} \right] \right\} - [1 + \varepsilon_V g_V(\chi, \eta, \varphi, T)] \tilde{I}_{000}(\chi, \eta, \varphi, \vartheta) \tilde{V}_{100}(\chi, \eta, \varphi, \vartheta); \\
 \frac{\partial \tilde{I}_{011}(\chi, \eta, \varphi, \vartheta)}{\partial \vartheta} &= \sqrt{\frac{D_{0I}}{D_{0V}}} \left[\frac{\partial^2 \tilde{I}_{011}(\chi, \eta, \varphi, \vartheta)}{\partial \chi^2} + \frac{\partial^2 \tilde{I}_{011}(\chi, \eta, \varphi, \vartheta)}{\partial \eta^2} + \frac{\partial^2 \tilde{I}_{011}(\chi, \eta, \varphi, \vartheta)}{\partial \varphi^2} \right] - \tilde{I}_{010}(\chi, \eta, \varphi, \vartheta) \times \\
 & \times [1 + \varepsilon_{I,I} g_{I,I}(\chi, \eta, \varphi, T)] \tilde{I}_{000}(\chi, \eta, \varphi, \vartheta) - [1 + \varepsilon_{I,V} g_{I,V}(\chi, \eta, \varphi, T)] \tilde{I}_{001}(\chi, \eta, \varphi, \vartheta) \tilde{V}_{000}(\chi, \eta, \varphi, \vartheta) \\
 \frac{\partial \tilde{V}_{011}(\chi, \eta, \varphi, \vartheta)}{\partial \vartheta} &= \sqrt{\frac{D_{0V}}{D_{0I}}} \left[\frac{\partial^2 \tilde{V}_{011}(\chi, \eta, \varphi, \vartheta)}{\partial \chi^2} + \frac{\partial^2 \tilde{V}_{011}(\chi, \eta, \varphi, \vartheta)}{\partial \eta^2} + \frac{\partial^2 \tilde{V}_{011}(\chi, \eta, \varphi, \vartheta)}{\partial \varphi^2} \right] - \tilde{V}_{010}(\chi, \eta, \varphi, \vartheta) \times \\
 & \times [1 + \varepsilon_{V,V} g_{V,V}(\chi, \eta, \varphi, T)] \tilde{V}_{000}(\chi, \eta, \varphi, \vartheta) - [1 + \varepsilon_{I,V} g_{I,V}(\chi, \eta, \varphi, t)] \tilde{I}_{000}(\chi, \eta, \varphi, \vartheta) \tilde{V}_{001}(\chi, \eta, \varphi, \vartheta); \\
 \frac{\partial \tilde{\rho}_{ijk}(\chi, \eta, \varphi, \vartheta)}{\partial \chi} \Big|_{x=0} &= 0, \quad \frac{\partial \tilde{\rho}_{ijk}(\chi, \eta, \varphi, \vartheta)}{\partial \chi} \Big|_{x=1} = 0, \quad \frac{\partial \tilde{\rho}_{ijk}(\chi, \eta, \varphi, \vartheta)}{\partial \eta} \Big|_{\eta=0} = 0, \quad \frac{\partial \tilde{\rho}_{ijk}(\chi, \eta, \varphi, \vartheta)}{\partial \eta} \Big|_{\eta=1} = 0, \\
 \frac{\partial \tilde{\rho}_{ijk}(\chi, \eta, \varphi, \vartheta)}{\partial \varphi} \Big|_{\varphi=0} &= 0, \quad \frac{\partial \tilde{\rho}_{ijk}(\chi, \eta, \varphi, \vartheta)}{\partial \varphi} \Big|_{\varphi=1} = 0 \quad (i \geq 0, j \geq 0, k \geq 0);
 \end{aligned}$$

$$\tilde{\rho}_{000}(\chi, \eta, \varphi, 0) = f_{\rho}(\chi, \eta, \varphi) / \rho^*, \quad \tilde{\rho}_{ijk}(\chi, \eta, \varphi, 0) = 0 \quad (i \geq 1, j \geq 1, k \geq 1).$$

Solutions of the above equations could be written as

$$\tilde{\rho}_{000}(\chi, \eta, \varphi, \vartheta) = \frac{1}{L} + \frac{2}{L} \sum_{n=1}^{\infty} F_{np} c(\chi) c(\eta) c(\varphi) e_{np}(\vartheta),$$

$$\text{where } F_{np} = \frac{1}{\rho^*} \int_0^1 \cos(\pi n u) \int_0^1 \cos(\pi n v) \int_0^1 \cos(\pi n w) f_{np}(u, v, w) dw dv du, \quad c_n(\chi) = \cos(\pi n \chi),$$

$$e_{nl}(\vartheta) = \exp\left(-\pi^2 n^2 \vartheta \sqrt{D_{0V}/D_{0I}}\right), \quad e_{nV}(\vartheta) = \exp\left(-\pi^2 n^2 \vartheta \sqrt{D_{0I}/D_{0V}}\right);$$

$$\begin{aligned} \tilde{I}_{i00}(\chi, \eta, \varphi, \vartheta) = & -2\pi \sqrt{\frac{D_{0I}}{D_{0V}}} \sum_{n=1}^{\infty} n c_n(\chi) c(\eta) c(\varphi) e_{nl}(\vartheta) \int_0^{\vartheta} e_{nl}(-\tau) \int_0^1 s_n(u) \int_0^1 c_n(v) \int_0^1 \frac{\partial \tilde{I}_{i-100}(u, v, w, \tau)}{\partial u} \times \\ & \times c_n(w) g_I(u, v, w, T) dw dv du d\tau - 2\pi \sqrt{\frac{D_{0I}}{D_{0V}}} \sum_{n=1}^{\infty} n c_n(\chi) c(\eta) c(\varphi) e_{nl}(\vartheta) \int_0^{\vartheta} e_{nl}(-\tau) \int_0^1 c_n(u) \int_0^1 s_n(v) \times \\ & \times \int_0^1 c_n(w) g_I(u, v, w, T) \frac{\partial \tilde{I}_{i-100}(u, v, w, \tau)}{\partial v} dw dv du d\tau - 2\pi \sqrt{\frac{D_{0I}}{D_{0V}}} \sum_{n=1}^{\infty} n c_n(\chi) c(\eta) c(\varphi) e_{nl}(\vartheta) \int_0^{\vartheta} e_{nl}(-\tau) \times \\ & \times \int_0^1 c_n(u) \int_0^1 c_n(v) \int_0^1 s_n(w) g_I(u, v, w, T) \frac{\partial \tilde{I}_{i-100}(u, v, w, \tau)}{\partial w} dw dv du d\tau, \quad i \geq 1, \end{aligned}$$

$$\begin{aligned} \tilde{V}_{i00}(\chi, \eta, \varphi, \vartheta) = & -2\pi \sqrt{\frac{D_{0V}}{D_{0I}}} \sum_{n=1}^{\infty} n c_n(\chi) c(\eta) c(\varphi) e_{nV}(\vartheta) \int_0^{\vartheta} e_{nV}(-\tau) \int_0^1 s_n(u) \int_0^1 c_n(v) \int_0^1 g_V(u, v, w, T) \times \\ & \times c_n(w) \frac{\partial \tilde{V}_{i-100}(u, \tau)}{\partial u} dw dv du d\tau - \sqrt{\frac{D_{0V}}{D_{0I}}} \sum_{n=1}^{\infty} n c_n(\chi) c(\eta) c(\varphi) e_{nV}(\vartheta) \int_0^{\vartheta} e_{nV}(-\tau) \int_0^1 c_n(u) \int_0^1 s_n(v) \times \\ & \times 2\pi \int_0^1 c_n(w) g_V(u, v, w, T) \frac{\partial \tilde{V}_{i-100}(u, \tau)}{\partial v} dw dv du d\tau - 2\pi \sqrt{\frac{D_{0V}}{D_{0I}}} \sum_{n=1}^{\infty} n c_n(\chi) c(\eta) c(\varphi) e_{nV}(\vartheta) \times \\ & \times \int_0^{\vartheta} e_{nV}(-\tau) \int_0^1 c_n(u) \int_0^1 c_n(v) \int_0^1 s_n(w) g_V(u, v, w, T) \frac{\partial \tilde{V}_{i-100}(u, \tau)}{\partial w} dw dv du d\tau, \quad i \geq 1, \end{aligned}$$

where $s_n(\chi) = \sin(\pi n \chi)$;

$$\begin{aligned} \tilde{\rho}_{010}(\chi, \eta, \varphi, \vartheta) = & -2 \sum_{n=1}^{\infty} c_n(\chi) c_n(\eta) c_n(\varphi) e_{np}(\vartheta) \int_0^{\vartheta} e_{np}(-\tau) \int_0^1 c_n(u) \int_0^1 c_n(v) \int_0^1 c_n(w) \times \\ & \times [1 + \varepsilon_{I,V} g_{I,V}(u, v, w, T)] \tilde{I}_{000}(u, v, w, \tau) \tilde{V}_{000}(u, v, w, \tau) dw dv du d\tau; \end{aligned}$$

$$\tilde{\rho}_{020}(\chi, \eta, \varphi, \vartheta) = -2 \sqrt{\frac{D_{0I}}{D_{0V}}} \sum_{n=1}^{\infty} c_n(\chi) c_n(\eta) c_n(\varphi) e_{n\rho}(\vartheta) \int_0^{\vartheta} e_{n\rho}(-\tau) \int_0^1 c_n(u) \int_0^1 c_n(v) \int_0^1 c_n(w) [1 + \varepsilon_{I,V} \times$$

$$\times g_{I,V}(u, v, w, T)] [\tilde{I}_{010}(u, v, w, \tau) \tilde{V}_{000}(u, v, w, \tau) + \tilde{I}_{000}(u, v, w, \tau) \tilde{V}_{010}(u, v, w, \tau)] d w d v d u d \tau;$$

$$\tilde{\rho}_{001}(\chi, \eta, \varphi, \vartheta) = -2 \sum_{n=1}^{\infty} c_n(\chi) c_n(\eta) c_n(\varphi) e_{n\rho}(\vartheta) \int_0^{\vartheta} e_{n\rho}(-\tau) \int_0^1 c_n(u) \int_0^1 c_n(v) \int_0^1 c_n(w) \times$$

$$\times [1 + \varepsilon_{\rho,\rho} g_{\rho,\rho}(u, v, w, T)] \tilde{\rho}_{000}^2(u, v, w, \tau) d w d v d u d \tau;$$

$$\tilde{\rho}_{002}(\chi, \eta, \varphi, \vartheta) = -2 \sum_{n=1}^{\infty} c_n(\chi) c_n(\eta) c_n(\varphi) e_{n\rho}(\vartheta) \int_0^{\vartheta} e_{n\rho}(-\tau) \int_0^1 c_n(u) \int_0^1 c_n(v) \int_0^1 c_n(w) \times$$

$$\times [1 + \varepsilon_{\rho,\rho} g_{\rho,\rho}(u, v, w, T)] \tilde{\rho}_{001}(u, v, w, \tau) \tilde{\rho}_{000}(u, v, w, \tau) d w d v d u d \tau;$$

$$\tilde{I}_{110}(\chi, \eta, \varphi, \vartheta) = -2\pi \sqrt{\frac{D_{0I}}{D_{0V}}} \sum_{n=1}^{\infty} n c_n(\chi) c_n(\eta) c_n(\varphi) e_{nI}(\vartheta) \int_0^{\vartheta} e_{nI}(-\tau) \int_0^1 s_n(u) \int_0^1 c_n(v) \int_0^1 c_n(u) \times$$

$$\times g_I(u, v, w, T) \frac{\partial \tilde{I}_{i-100}(u, v, w, \tau)}{\partial u} d w d v d u d \tau - 2\pi \sqrt{\frac{D_{0I}}{D_{0V}}} \sum_{n=1}^{\infty} n c_n(\chi) c_n(\eta) c_n(\varphi) e_{nI}(\vartheta) \times$$

$$\times \int_0^{\vartheta} e_{nI}(-\tau) \int_0^1 c_n(u) \int_0^1 s_n(v) \int_0^1 c_n(u) g_I(u, v, w, T) \frac{\partial \tilde{I}_{i-100}(u, v, w, \tau)}{\partial v} d w d v d u d \tau - 2\pi \sqrt{\frac{D_{0I}}{D_{0V}}} \times$$

$$\times \sum_{n=1}^{\infty} n e_{nI}(\vartheta) \int_0^{\vartheta} e_{nI}(-\tau) \int_0^1 c_n(u) \int_0^1 c_n(v) \int_0^1 s_n(u) g_I(u, v, w, T) \frac{\partial \tilde{I}_{i-100}(u, v, w, \tau)}{\partial w} d w d v d u d \tau \times$$

$$\times c_n(\chi) c_n(\eta) c_n(\varphi) - 2 \sum_{n=1}^{\infty} c_n(\chi) e_{nI}(\vartheta) c_n(\eta) c_n(\varphi) \int_0^{\vartheta} e_{nI}(-\tau) \int_0^1 c_n(u) \int_0^1 c_n(v) \int_0^1 c_n(v) [1 + \varepsilon_{I,V} \times$$

$$\times g_{I,V}(u, v, w, T)] [\tilde{I}_{100}(u, v, w, \tau) \tilde{V}_{000}(u, v, w, \tau) + \tilde{I}_{000}(u, v, w, \tau) \tilde{V}_{100}(u, v, w, \tau)] d w d v d u d \tau$$

$$\tilde{V}_{110}(\chi, \eta, \varphi, \vartheta) = -2\pi \sqrt{\frac{D_{0V}}{D_{0I}}} \sum_{n=1}^{\infty} n c_n(\chi) c_n(\eta) c_n(\varphi) e_{nV}(\vartheta) \int_0^{\vartheta} e_{nV}(-\tau) \int_0^1 s_n(u) \int_0^1 c_n(v) \int_0^1 c_n(u) \times$$

$$\times g_V(u, v, w, T) \frac{\partial \tilde{V}_{i-100}(u, v, w, \tau)}{\partial u} d w d v d u d \tau - 2\pi \sqrt{\frac{D_{0V}}{D_{0I}}} \sum_{n=1}^{\infty} n c_n(\chi) c_n(\eta) c_n(\varphi) e_{nV}(\vartheta) \times$$

$$\begin{aligned}
 & \times \int_0^\vartheta e_{nV}(-\tau) \int_0^1 c_n(u) \int_0^1 s_n(v) \int_0^1 c_n(u) g_V(u, v, w, T) \frac{\partial \tilde{V}_{i-100}(u, v, w, \tau)}{\partial v} d w d v d u d \tau - 2\pi \sqrt{\frac{D_{0V}}{D_{0I}}} \times \\
 & \times \sum_{n=1}^{\infty} n e_{nV}(\vartheta) \int_0^\vartheta e_{nV}(-\tau) \int_0^1 c_n(u) \int_0^1 c_n(v) \int_0^1 s_n(u) g_V(u, v, w, T) \frac{\partial \tilde{V}_{i-100}(u, v, w, \tau)}{\partial w} d w d v d u d \tau \times \\
 & \times c_n(\chi) c_n(\eta) c_n(\varphi) - 2 \sum_{n=1}^{\infty} c_n(\chi) e_{nI}(\vartheta) c_n(\eta) c_n(\varphi) \int_0^\vartheta e_{nV}(-\tau) \int_0^1 c_n(u) \int_0^1 c_n(v) \int_0^1 [1 + \varepsilon_{I,V} g_{I,V}(u, v, w, T)] \times \\
 & \times c_n(w) [\tilde{I}_{100}(u, v, w, \tau) \tilde{V}_{000}(u, v, w, \tau) + \tilde{I}_{000}(u, v, w, \tau) \tilde{V}_{100}(u, v, w, \tau)] d w d v d u d \tau ; \\
 \tilde{I}_{101}(\chi, \eta, \varphi, \vartheta) & = -2\pi \sqrt{\frac{D_{0I}}{D_{0V}}} \sum_{n=1}^{\infty} n c_n(\chi) c_n(\eta) c_n(\varphi) e_{nI}(\vartheta) \int_0^\vartheta e_{nI}(-\tau) \int_0^1 s_n(u) \int_0^1 c_n(v) \int_0^1 g_I(u, v, w, T) \times \\
 & \times c_n(w) \frac{\partial \tilde{I}_{001}(u, v, w, \tau)}{\partial u} d w d v d u d \tau - 2\pi \sqrt{\frac{D_{0I}}{D_{0V}}} \sum_{n=1}^{\infty} n c_n(\chi) c_n(\eta) c_n(\varphi) e_{nI}(\vartheta) \times \\
 & \times \int_0^1 s_n(v) \int_0^1 c_n(w) g_I(u, v, w, T) \frac{\partial \tilde{I}_{001}(u, v, w, \tau)}{\partial v} d w d v d u d \tau - 2\pi \sqrt{\frac{D_{0I}}{D_{0V}}} \sum_{n=1}^{\infty} n e_{nI}(\vartheta) c_n(\chi) c_n(\eta) c_n(\varphi) \times \\
 & \times \int_0^\vartheta e_{nI}(-\tau) \int_0^1 c_n(u) \int_0^1 c_n(v) \int_0^1 s_n(w) g_I(u, v, w, T) \frac{\partial \tilde{I}_{001}(u, v, w, \tau)}{\partial w} d w d v d u d \tau - 2 \sum_{n=1}^{\infty} c_n(\chi) c_n(\eta) c_n(\varphi) \times \\
 & \times e_{nI}(\vartheta) \int_0^\vartheta e_{nI}(-\tau) \int_0^1 c_n(u) \int_0^1 c_n(v) \int_0^1 c_n(w) \left[\frac{1 + \varepsilon_{I,V} g_{I,V}}{(u, v, w, T)} \right] \tilde{I}_{100}(u, v, w, \tau) \tilde{V}_{000}(u, v, w, \tau) d w d v d u d \tau \\
 \tilde{V}_{101}(\chi, \eta, \varphi, \vartheta) & = -2\pi \sqrt{\frac{D_{0V}}{D_{0I}}} \sum_{n=1}^{\infty} n c_n(\chi) c_n(\eta) c_n(\varphi) e_{nV}(\vartheta) \int_0^\vartheta e_{nV}(-\tau) \int_0^1 s_n(u) \int_0^1 c_n(v) \int_0^1 g_V(u, v, w, T) \times \\
 & \times c_n(w) \frac{\partial \tilde{V}_{001}(u, v, w, \tau)}{\partial u} d w d v d u d \tau - 2\pi \sqrt{\frac{D_{0V}}{D_{0I}}} \sum_{n=1}^{\infty} n c_n(\chi) c_n(\eta) c_n(\varphi) e_{nV}(\vartheta) \int_0^\vartheta e_{nV}(-\tau) \int_0^1 c_n(u) \times \\
 & \times \int_0^1 s_n(v) \int_0^1 c_n(w) g_V(u, v, w, T) \frac{\partial \tilde{V}_{001}(u, v, w, \tau)}{\partial v} d w d v d u d \tau - 2\pi \sqrt{\frac{D_{0V}}{D_{0I}}} \sum_{n=1}^{\infty} n e_{nV}(\vartheta) c_n(\chi) c_n(\eta) c_n(\varphi) \times \\
 & \times \int_0^\vartheta e_{nV}(-\tau) \int_0^1 c_n(u) \int_0^1 c_n(v) \int_0^1 s_n(w) g_V(u, v, w, T) \frac{\partial \tilde{V}_{001}(u, v, w, \tau)}{\partial w} d w d v d u d \tau - 2 \sum_{n=1}^{\infty} c_n(\chi) c_n(\eta) c_n(\varphi) \times
 \end{aligned}$$

$$\begin{aligned} & \times e_{nV}(\vartheta) \int_0^{\vartheta} e_{nV}(-\tau) \int_0^1 c_n(u) \int_0^1 c_n(v) \int_0^1 c_n(w) \left[\frac{1 + \varepsilon_{I,V} g_{I,V}}{(u,v,w,T)} \right] \tilde{I}_{100}(u,v,w,\tau) \tilde{V}_{000}(u,v,w,\tau) dw dv du d\tau; \\ \tilde{I}_{011}(\chi, \eta, \varphi, \vartheta) &= -2 \sum_{n=1}^{\infty} c_n(\chi) c_n(\eta) c_n(\varphi) e_{nI}(\vartheta) \int_0^{\vartheta} e_{nI}(-\tau) \int_0^1 c_n(u) \int_0^1 c_n(v) \int_0^1 c_n(w) \left\{ \tilde{I}_{000}(u,v,w,\tau) \times \right. \\ & \times \left[1 + \varepsilon_{I,I} g_{I,I}(u,v,w,T) \right] \tilde{I}_{010}(u,v,w,\tau) + \left. \left[\frac{1 + \varepsilon_{I,V} g_{I,V}}{(u,v,w,T)} \right] \tilde{I}_{001}(u,v,w,\tau) \tilde{V}_{000}(u,v,w,\tau) \right\} dw dv du d\tau \\ \tilde{V}_{011}(\chi, \eta, \varphi, \vartheta) &= -2 \sum_{n=1}^{\infty} c_n(\chi) c_n(\eta) c_n(\varphi) e_{nV}(\vartheta) \int_0^{\vartheta} e_{nV}(-\tau) \int_0^1 c_n(u) \int_0^1 c_n(v) \int_0^1 c_n(w) \left\{ \tilde{I}_{000}(u,v,w,\tau) \times \right. \\ & \times \left[1 + \varepsilon_{I,I} g_{I,I}(u,v,w,T) \right] \tilde{I}_{010}(u,v,w,\tau) + \left. \left[\frac{1 + \varepsilon_{I,V} g_{I,V}}{(u,v,w,T)} \right] \tilde{I}_{001}(u,v,w,\tau) \tilde{V}_{000}(u,v,w,\tau) \right\} dw dv du d\tau. \end{aligned}$$

Equations for functions $\Phi_{\rho_i}(x,y,z,t)$, $i \geq 0$ to describe concentrations of simplest complexes of radiation defects.

$$\begin{aligned} \frac{\partial \Phi_{I0}(x,y,z,t)}{\partial t} &= D_{0\Phi I} \left[\frac{\partial^2 \Phi_{I0}(x,y,z,t)}{\partial x^2} + \frac{\partial^2 \Phi_{I0}(x,y,z,t)}{\partial y^2} + \frac{\partial^2 \Phi_{I0}(x,y,z,t)}{\partial z^2} \right] + \\ & + k_{I,I}(x,y,z,T) I^2(x,y,z,t) - k_I(x,y,z,T) I(x,y,z,t) \\ \frac{\partial \Phi_{V0}(x,y,z,t)}{\partial t} &= D_{0\Phi V} \left[\frac{\partial^2 \Phi_{V0}(x,y,z,t)}{\partial x^2} + \frac{\partial^2 \Phi_{V0}(x,y,z,t)}{\partial y^2} + \frac{\partial^2 \Phi_{V0}(x,y,z,t)}{\partial z^2} \right] + \\ & + k_{V,V}(x,y,z,T) V^2(x,y,z,t) - k_V(x,y,z,T) V(x,y,z,t); \\ \frac{\partial \Phi_{Ii}(x,y,z,t)}{\partial t} &= D_{0\Phi I} \left[\frac{\partial^2 \Phi_{Ii}(x,y,z,t)}{\partial x^2} + \frac{\partial^2 \Phi_{Ii}(x,y,z,t)}{\partial y^2} + \frac{\partial^2 \Phi_{Ii}(x,y,z,t)}{\partial z^2} \right] + \\ & + D_{0\Phi I} \left\{ \frac{\partial}{\partial x} \left[g_{\Phi I}(x,y,z,T) \frac{\partial \Phi_{Ii-1}(x,y,z,t)}{\partial x} \right] + \frac{\partial}{\partial y} \left[g_{\Phi I}(x,y,z,T) \frac{\partial \Phi_{Ii-1}(x,y,z,t)}{\partial y} \right] \right\} + \\ & + \frac{\partial}{\partial z} \left[g_{\Phi I}(x,y,z,T) \frac{\partial \Phi_{Ii-1}(x,y,z,t)}{\partial z} \right] \Bigg\}, i \geq 1, \\ \frac{\partial \Phi_{Vi}(x,y,z,t)}{\partial t} &= D_{0\Phi V} \left[\frac{\partial^2 \Phi_{Vi}(x,y,z,t)}{\partial x^2} + \frac{\partial^2 \Phi_{Vi}(x,y,z,t)}{\partial y^2} + \frac{\partial^2 \Phi_{Vi}(x,y,z,t)}{\partial z^2} \right] + \end{aligned}$$

$$+D_{0\Phi^V} \left\{ \frac{\partial}{\partial x} \left[g_{\Phi^V}(x, y, z, T) \frac{\partial \Phi_{V_{i-1}}(x, y, z, t)}{\partial x} \right] + \frac{\partial}{\partial y} \left[g_{\Phi^V}(x, y, z, T) \frac{\partial \Phi_{V_{i-1}}(x, y, z, t)}{\partial y} \right] + \frac{\partial}{\partial z} \left[g_{\Phi^V}(x, y, z, T) \frac{\partial \Phi_{V_{i-1}}(x, y, z, t)}{\partial z} \right] \right\}, i \geq 1;$$

Boundary and initial conditions for the functions take the form

$$\frac{\partial \Phi_{\rho i}(x, y, z, t)}{\partial x} \Big|_{x=0} = 0, \frac{\partial \Phi_{\rho i}(x, y, z, t)}{\partial x} \Big|_{x=L_x} = 0, \frac{\partial \Phi_{\rho i}(x, y, z, t)}{\partial y} \Big|_{y=0} = 0, \frac{\partial \Phi_{\rho i}(x, y, z, t)}{\partial y} \Big|_{y=L_y} = 0,$$

$$\frac{\partial \Phi_{\rho i}(x, y, z, t)}{\partial z} \Big|_{z=0} = 0, \frac{\partial \Phi_{\rho i}(x, y, z, t)}{\partial z} \Big|_{z=L_z} = 0, i \geq 0; \Phi_{\rho}(x, y, z, 0) = f_{\Phi_{\rho}}(x, y, z),$$

$$\Phi_{\rho i}(x, y, z, 0) = 0, i \geq 1.$$

Solutions of the above equations could be written as

$$\Phi_{\rho 0}(x, y, z, t) = \frac{1}{L_x L_y L_z} + \frac{2}{L_x L_y L_z} \sum_{n=1}^{\infty} F_{n\Phi_{\rho}} c_n(x) c_n(y) c_n(z) e_{n\Phi_{\rho}}(t) + \frac{2}{L} \sum_{n=1}^{\infty} n c_n(x) c_n(y) c_n(z) \times \\ \times e_{\Phi_{\rho n}}(t) \int_0^t e_{\Phi_{\rho n}}(-\tau) \int_0^{L_x} c_n(u) \int_0^{L_y} c_n(v) \int_0^{L_z} c_n(w) [k_{I,I}(u, v, w, T) I^2(u, v, w, \tau) - \\ - k_I(u, v, w, T) I(u, v, w, \tau)] d w d v d u d \tau,$$

$$\text{where } F_{n\Phi_{\rho}} = \int_0^{L_x} c_n(u) \int_0^{L_y} c_n(v) \int_0^{L_z} c_n(w) f_{\Phi_{\rho}}(u, v, w) d w d v d u, e_{n\Phi_{\rho}}(t) = \exp[-\pi^2 n^2 D_{0\Phi_{\rho}} t (L_x^2 + L_y^2 + L_z^2)],$$

$$c_n(x) = \cos(\pi n x / L_x);$$

$$\Phi_{\rho i}(x, y, z, t) = -\frac{2\pi}{L_x^2 L_y L_z} \sum_{n=1}^{\infty} n c_n(x) c_n(y) c_n(z) e_{\Phi_{\rho n}}(t) \int_0^t e_{\Phi_{\rho n}}(-\tau) \int_0^{L_x} s_n(u) \int_0^{L_y} c_n(v) \int_0^{L_z} g_{\Phi_{\rho}}(u, v, w, T) \times \\ \times c_n(w) \frac{\partial \Phi_{I_{\rho}^{i-1}}(u, v, w, \tau)}{\partial u} d w d v d u d \tau - \frac{2\pi}{L_x L_y^2 L_z} \sum_{n=1}^{\infty} n c_n(x) c_n(y) c_n(z) e_{\Phi_{\rho n}}(t) \int_0^t e_{\Phi_{\rho n}}(-\tau) \times \\ \times \int_0^t e_{\Phi_{\rho n}}(-\tau) \int_0^{L_x} c_n(u) \int_0^{L_y} s_n(v) \int_0^{L_z} c_n(w) g_{\Phi_{\rho}}(u, v, w, T) \frac{\partial \Phi_{I_{\rho}^{i-1}}(u, v, w, \tau)}{\partial v} d w d v d u d \tau - \frac{2\pi}{L_x L_y L_z^2} \sum_{n=1}^{\infty} n \times \\ \times e_{\Phi_{\rho n}}(t) \int_0^t e_{\Phi_{\rho n}}(-\tau) \int_0^{L_x} c_n(u) \int_0^{L_y} c_n(v) \int_0^{L_z} s_n(w) \frac{\partial \Phi_{I_{\rho}^{i-1}}(u, v, w, \tau)}{\partial w} g_{\Phi_{\rho}}(u, v, w, T) d w d v d u d \tau \times \\ \times c_n(x) c_n(y) c_n(z), i \geq 1,$$

$$\text{where } s_n(x) = \sin(\pi n x / L_x).$$

Equations for the functions $C_{ij}(x,y,z,t)$ ($i \geq 0, j \geq 0$), boundary and initial conditions could be written as

$$\frac{\partial C_{00}(x,y,z,t)}{\partial t} = D_{0L} \frac{\partial^2 C_{00}(x,y,z,t)}{\partial x^2} + D_{0L} \frac{\partial^2 C_{00}(x,y,z,t)}{\partial y^2} + D_{0L} \frac{\partial^2 C_{00}(x,y,z,t)}{\partial z^2};$$

$$\frac{\partial C_{i0}(x,y,z,t)}{\partial t} = D_{0L} \left[\frac{\partial^2 C_{i0}(x,y,z,t)}{\partial x^2} + \frac{\partial^2 C_{i0}(x,y,z,t)}{\partial y^2} + \frac{\partial^2 C_{i0}(x,y,z,t)}{\partial z^2} \right] +$$

$$+ D_{0L} \frac{\partial}{\partial x} \left[g_L(x,y,z,T) \frac{\partial C_{i-10}(x,y,z,t)}{\partial x} \right] + D_{0L} \frac{\partial}{\partial y} \left[g_L(x,y,z,T) \frac{\partial C_{i-10}(x,y,z,t)}{\partial y} \right] +$$

$$+ D_{0L} \frac{\partial}{\partial z} \left[g_L(x,y,z,T) \frac{\partial C_{i-10}(x,y,z,t)}{\partial z} \right], i \geq 1;$$

$$\frac{\partial C_{01}(x,y,z,t)}{\partial t} = D_{0L} \frac{\partial^2 C_{01}(x,y,z,t)}{\partial x^2} + D_{0L} \frac{\partial^2 C_{01}(x,y,z,t)}{\partial y^2} + D_{0L} \frac{\partial^2 C_{01}(x,y,z,t)}{\partial z^2} +$$

$$+ D_{0L} \frac{\partial}{\partial x} \left[\frac{C_{00}^\gamma(x,y,z,t)}{P^\gamma(x,y,z,T)} \frac{\partial C_{00}(x,y,z,t)}{\partial x} \right] + D_{0L} \frac{\partial}{\partial y} \left[\frac{C_{00}^\gamma(x,y,z,t)}{P^\gamma(x,y,z,T)} \frac{\partial C_{00}(x,y,z,t)}{\partial y} \right] +$$

$$+ D_{0L} \frac{\partial}{\partial z} \left[\frac{C_{00}^\gamma(x,y,z,t)}{P^\gamma(x,y,z,T)} \frac{\partial C_{00}(x,y,z,t)}{\partial z} \right];$$

$$\frac{\partial C_{02}(x,y,z,t)}{\partial t} = D_{0L} \frac{\partial^2 C_{02}(x,y,z,t)}{\partial x^2} + D_{0L} \frac{\partial^2 C_{02}(x,y,z,t)}{\partial y^2} + D_{0L} \frac{\partial^2 C_{02}(x,y,z,t)}{\partial z^2} +$$

$$+ D_{0L} \left\{ \frac{\partial}{\partial x} \left[C_{01}(x,y,z,t) \frac{C_{00}^{\gamma-1}(x,y,z,t)}{P^\gamma(x,y,z,T)} \frac{\partial C_{00}(x,y,z,t)}{\partial x} \right] + \frac{\partial}{\partial y} \left[C_{01}(x,y,z,t) \frac{C_{00}^{\gamma-1}(x,y,z,t)}{P^\gamma(x,y,z,T)} \times \right. \right.$$

$$\left. \times \frac{\partial C_{00}(x,y,z,t)}{\partial y} \right] + \frac{\partial}{\partial z} \left[C_{01}(x,y,z,t) \frac{C_{00}^{\gamma-1}(x,y,z,t)}{P^\gamma(x,y,z,T)} \frac{\partial C_{00}(x,y,z,t)}{\partial z} \right] \left. \right\} +$$

$$\times \frac{\partial C_{00}(x,y,z,t)}{\partial y} \left. \right] + \frac{\partial}{\partial z} \left[C_{01}(x,y,z,t) \frac{C_{00}^{\gamma-1}(x,y,z,t)}{P^\gamma(x,y,z,T)} \frac{\partial C_{00}(x,y,z,t)}{\partial z} \right] \left. \right\} + D_{0L} \left\{ \frac{\partial}{\partial x} \left[\frac{C_{00}^\gamma(x,y,z,t)}{P^\gamma(x,y,z,T)} \times \right. \right.$$

$$\left. \times \frac{\partial C_{01}(x,y,z,t)}{\partial x} \right] + \frac{\partial}{\partial y} \left[\frac{C_{00}^\gamma(x,y,z,t)}{P^\gamma(x,y,z,T)} \frac{\partial C_{01}(x,y,z,t)}{\partial y} \right] + \frac{\partial}{\partial z} \left[\frac{C_{00}^\gamma(x,y,z,t)}{P^\gamma(x,y,z,T)} \frac{\partial C_{01}(x,y,z,t)}{\partial z} \right] \left. \right\};$$

$$\frac{\partial C_{11}(x,y,z,t)}{\partial t} = D_{0L} \frac{\partial^2 C_{11}(x,y,z,t)}{\partial x^2} + D_{0L} \frac{\partial^2 C_{11}(x,y,z,t)}{\partial y^2} + D_{0L} \frac{\partial^2 C_{11}(x,y,z,t)}{\partial z^2} +$$

$$\begin{aligned}
 & + \left\{ \frac{\partial}{\partial x} \left[C_{10}(x, y, z, t) \frac{C_{00}^{\gamma-1}(x, y, z, t)}{P^\gamma(x, y, z, T)} \frac{\partial C_{00}(x, y, z, t)}{\partial x} \right] + \frac{\partial}{\partial y} \left[C_{10}(x, y, z, t) \frac{C_{00}^{\gamma-1}(x, y, z, t)}{P^\gamma(x, y, z, T)} \times \right. \right. \\
 & \times \left. \left. \frac{\partial C_{00}(x, y, z, t)}{\partial y} \right] + \frac{\partial}{\partial z} \left[C_{10}(x, y, z, t) \frac{C_{00}^{\gamma-1}(x, y, z, t)}{P^\gamma(x, y, z, T)} \frac{\partial C_{00}(x, y, z, t)}{\partial z} \right] \right\} D_{0L} + \\
 & + D_{0L} \left\{ \frac{\partial}{\partial x} \left[\frac{C_{00}^\gamma(x, y, z, t)}{P^\gamma(x, y, z, T)} \frac{\partial C_{10}(x, y, z, t)}{\partial x} \right] + \frac{\partial}{\partial y} \left[\frac{C_{00}^\gamma(x, y, z, t)}{P^\gamma(x, y, z, T)} \frac{\partial C_{10}(x, y, z, t)}{\partial y} \right] + \right. \\
 & + \left. \frac{\partial}{\partial z} \left[\frac{C_{00}^\gamma(x, y, z, t)}{P^\gamma(x, y, z, T)} \frac{\partial C_{10}(x, y, z, t)}{\partial z} \right] \right\} + D_{0L} \left\{ \frac{\partial}{\partial x} \left[g_L(x, y, z, T) \frac{\partial C_{01}(x, y, z, t)}{\partial x} \right] + \right. \\
 & + \left. \frac{\partial}{\partial y} \left[g_L(x, y, z, T) \frac{\partial C_{01}(x, y, z, t)}{\partial y} \right] + \frac{\partial}{\partial z} \left[g_L(x, y, z, T) \frac{\partial C_{01}(x, y, z, t)}{\partial z} \right] \right\};
 \end{aligned}$$

$$\left. \frac{\partial C_{ij}(x, y, z, t)}{\partial x} \right|_{x=0} = 0, \left. \frac{\partial C_{ij}(x, y, z, t)}{\partial x} \right|_{x=L_x} = 0, \left. \frac{\partial C_{ij}(x, y, z, t)}{\partial y} \right|_{y=0} = 0, \left. \frac{\partial C_{ij}(x, y, z, t)}{\partial y} \right|_{y=L_y} = 0,$$

$$\left. \frac{\partial C_{ij}(x, y, z, t)}{\partial z} \right|_{z=0} = 0, \left. \frac{\partial C_{ij}(x, y, z, t)}{\partial z} \right|_{z=L_z} = 0, i \geq 0, j \geq 0;$$

$C_{00}(x, y, z, 0) = f_C(x, y, z)$, $C_{ij}(x, y, z, 0) = 0$, $i \geq 1, j \geq 1$.

Functions $C_{ij}(x, y, z, t)$ ($i \geq 0, j \geq 0$) could be approximated by the following series during solutions of the above equations

$$C_{00}(x, y, z, t) = \frac{F_{0C}}{L_x L_y L_z} + \frac{2}{L_x L_y L_z} \sum_{n=1}^{\infty} F_{nC} c_n(x) c_n(y) c_n(z) e_{nC}(t).$$

Here $e_{nC}(t) = \exp \left[-\pi^2 n^2 D_{0C} t \left(\frac{1}{L_x^2} + \frac{1}{L_y^2} + \frac{1}{L_z^2} \right) \right]$, $F_{nC} = \int_0^{L_x} c_n(u) \int_0^{L_y} c_n(v) \int_0^{L_z} f_C(u, v, w) c_n(w) dw dv du$;

$$C_{i0}(x, y, z, t) = -\frac{2\pi}{L_x^2 L_y L_z} \sum_{n=1}^{\infty} n F_{nC} c_n(x) c_n(y) c_n(z) e_{nC}(t) \int_0^t e_{nC}(-\tau) \int_0^{L_x} s_n(u) \int_0^{L_y} c_n(v) \int_0^{L_z} g_L(u, v, w, T) \times$$

$$\times c_n(w) \frac{\partial C_{i-10}(u, v, w, \tau)}{\partial u} dw dv du d\tau - \frac{2\pi}{L_x L_y^2 L_z} \sum_{n=1}^{\infty} n F_{nC} c_n(x) c_n(y) c_n(z) e_{nC}(t) \int_0^t e_{nC}(-\tau) \times$$

$$\times \int_0^{L_x} c_n(u) \int_0^{L_y} s_n(v) \int_0^{L_z} c_n(v) g_L(u, v, w, T) \frac{\partial C_{i-10}(u, v, w, \tau)}{\partial v} dw dv du d\tau - \frac{2\pi}{L_x L_y L_z^2} \sum_{n=1}^{\infty} n F_{nC} e_{nC}(t) \times$$

$$\times c_n(x) c_n(y) c_n(z) \int_0^t e_{nC}(-\tau) \int_0^{L_x} c_n(u) \int_0^{L_y} c_n(v) \int_0^{L_z} s_n(v) g_L(u, v, w, T) \frac{\partial C_{i-10}(u, v, w, \tau)}{\partial w} dw dv du d\tau, i \geq 1;$$

$$\begin{aligned}
 C_{01}(x, y, z, t) = & -\frac{2\pi}{L_x^2 L_y L_z} \sum_{n=1}^{\infty} n F_{nC} c_n(x) c_n(y) c_n(z) e_{nC}(t) \int_0^t e_{nC}(-\tau) \int_0^{L_x} s_n(u) \int_0^{L_y} c_n(v) \int_0^{L_z} c_n(w) \times \\
 & \times \frac{C_{00}^\gamma(u, v, w, \tau)}{P^\gamma(u, v, w, T)} \frac{\partial C_{00}(u, v, w, \tau)}{\partial u} d w d v d u d \tau - \frac{2\pi}{L_x L_y^2 L_z} \sum_{n=1}^{\infty} n F_{nC} c_n(x) c_n(y) c_n(z) e_{nC}(t) \times \\
 & \times \int_0^t e_{nC}(-\tau) \int_0^{L_x} c_n(u) \int_0^{L_y} s_n(v) \int_0^{L_z} c_n(w) \frac{C_{00}^\gamma(u, v, w, \tau)}{P^\gamma(u, v, w, T)} \frac{\partial C_{00}(u, v, w, \tau)}{\partial v} d w d v d u d \tau - \frac{2\pi}{L_x L_y L_z^2} \sum_{n=1}^{\infty} n e_{nC}(t) \times \\
 & \times F_{nC} c_n(x) c_n(y) c_n(z) \int_0^t e_{nC}(-\tau) \int_0^{L_x} c_n(u) \int_0^{L_y} c_n(v) \int_0^{L_z} s_n(w) \frac{C_{00}^\gamma(u, v, w, \tau)}{P^\gamma(u, v, w, T)} \frac{\partial C_{00}(u, v, w, \tau)}{\partial w} d w d v d u d \tau ; \\
 C_{02}(x, y, z, t) = & -\frac{2\pi}{L_x^2 L_y L_z} \sum_{n=1}^{\infty} n F_{nC} c_n(x) c_n(y) c_n(z) e_{nC}(t) \int_0^t e_{nC}(-\tau) \int_0^{L_x} s_n(u) \int_0^{L_y} c_n(v) \int_0^{L_z} c_n(w) \times \\
 & \times C_{01}(u, v, w, \tau) \frac{C_{00}^{\gamma-1}(u, v, w, \tau)}{P^\gamma(u, v, w, T)} \frac{\partial C_{00}(u, v, w, \tau)}{\partial u} d w d v d u d \tau - \frac{2\pi}{L_x L_y^2 L_z} \sum_{n=1}^{\infty} F_{nC} c_n(x) c_n(y) \times \\
 & \times n c_n(z) e_{nC}(t) \int_0^t e_{nC}(-\tau) \int_0^{L_x} c_n(u) \int_0^{L_y} s_n(v) \int_0^{L_z} C_{01}(u, v, w, \tau) \frac{C_{00}^{\gamma-1}(u, v, w, \tau)}{P^\gamma(u, v, w, T)} \frac{\partial C_{00}(u, v, w, \tau)}{\partial v} \times \\
 & \times c_n(w) d w d v d u d \tau - \frac{2\pi}{L_x L_y L_z^2} \sum_{n=1}^{\infty} n F_{nC} c_n(x) c_n(y) c_n(z) e_{nC}(t) \int_0^t e_{nC}(-\tau) \int_0^{L_x} c_n(u) \int_0^{L_y} c_n(v) \times \\
 & \times \int_0^{L_z} s_n(w) C_{01}(u, v, w, \tau) \frac{C_{00}^{\gamma-1}(u, v, w, \tau)}{P^\gamma(u, v, w, T)} \frac{\partial C_{00}(u, v, w, \tau)}{\partial w} d w d v d u d \tau - \frac{2\pi}{L_x^2 L_y L_z} \sum_{n=1}^{\infty} n c_n(x) \times \\
 & \times F_{nC} c_n(y) c_n(z) e_{nC}(t) \int_0^t e_{nC}(-\tau) \int_0^{L_x} s_n(u) \int_0^{L_y} c_n(v) \int_0^{L_z} c_n(w) C_{01}(u, v, w, \tau) \frac{\partial C_{00}(u, v, w, \tau)}{\partial u} \times \\
 & \times \frac{C_{00}^{\gamma-1}(u, v, w, \tau)}{P^\gamma(u, v, w, T)} d w d v d u d \tau - \frac{2\pi}{L_x L_y^2 L_z} \sum_{n=1}^{\infty} n F_{nC} c_n(x) c_n(y) c_n(z) e_{nC}(t) \int_0^t e_{nC}(-\tau) \int_0^{L_x} c_n(u) \times \\
 & \times \int_0^{L_y} s_n(v) \int_0^{L_z} c_n(w) C_{01}(u, v, w, \tau) \frac{C_{00}^{\gamma-1}(u, v, w, \tau)}{P^\gamma(u, v, w, T)} \frac{\partial C_{00}(u, v, w, \tau)}{\partial v} d w d v d u d \tau - \frac{2\pi}{L_x L_y L_z^2} \sum_{n=1}^{\infty} n \times \\
 & \times F_{nC} c_n(x) c_n(y) c_n(z) e_{nC}(t) \int_0^t e_{nC}(-\tau) \int_0^{L_x} c_n(u) \int_0^{L_y} c_n(v) \int_0^{L_z} s_n(w) C_{01}(u, v, w, \tau) \frac{C_{00}^{\gamma-1}(u, v, w, \tau)}{P^\gamma(u, v, w, T)} \times
 \end{aligned}$$

$$\begin{aligned}
 & \times \frac{\partial C_{00}(u, v, w, \tau)}{\partial w} d w d v d u d \tau - \frac{2\pi}{L_x^2 L_y L_z} \sum_{n=1}^{\infty} F_{nC} c_n(x) c_n(y) c_n(z) e_{nC}(t) \int_0^t e_{nC}(-\tau) \int_0^{L_x} s_n(u) \times \\
 & \times n \int_0^{L_y} c_n(v) \int_0^{L_z} c_n(w) \frac{C_{00}^\gamma(u, v, w, \tau)}{P^\gamma(u, v, w, T)} \frac{\partial C_{01}(u, v, w, \tau)}{\partial u} d w d v d u d \tau - \frac{2\pi}{L_x L_y^2 L_z} \sum_{n=1}^{\infty} c_n(x) e_{nC}(t) \times \\
 & \times F_{nC} c_n(y) \int_0^t e_{nC}(-\tau) \int_0^{L_x} c_n(u) \int_0^{L_y} s_n(v) \int_0^{L_z} c_n(w) \frac{C_{00}^\gamma(u, v, w, \tau)}{P^\gamma(u, v, w, T)} \frac{\partial C_{01}(u, v, w, \tau)}{\partial v} d w d v d u d \tau \times \\
 & \times n c_n(z) - \frac{2\pi}{L_x L_y L_z^2} \sum_{n=1}^{\infty} n F_{nC} c_n(x) c_n(y) c_n(z) e_{nC}(t) \int_0^t e_{nC}(-\tau) \int_0^{L_x} c_n(u) \int_0^{L_y} c_n(v) \int_0^{L_z} s_n(w) \times \\
 & \times \frac{C_{00}^\gamma(u, v, w, \tau)}{P^\gamma(u, v, w, T)} \frac{\partial C_{01}(u, v, w, \tau)}{\partial w} d w d v d u d \tau ; \\
 C_{11}(x, y, z, t) = & - \frac{2\pi}{L_x^2 L_y L_z} \sum_{n=1}^{\infty} n F_{nC} c_n(x) c_n(y) c_n(z) e_{nC}(t) \int_0^t e_{nC}(-\tau) \int_0^{L_x} s_n(u) \int_0^{L_y} c_n(v) \int_0^{L_z} c_n(w) \times \\
 & \times g_L(u, v, w, T) \frac{\partial C_{01}(u, v, w, \tau)}{\partial u} d w d v d u d \tau - \frac{2\pi}{L_x L_y^2 L_z} \sum_{n=1}^{\infty} n F_{nC} c_n(x) c_n(y) c_n(z) e_{nC}(t) \times \\
 & \times \int_0^t e_{nC}(-\tau) \int_0^{L_x} c_n(u) \int_0^{L_y} s_n(v) \int_0^{L_z} c_n(w) g_L(u, v, w, T) \frac{\partial C_{01}(u, v, w, \tau)}{\partial v} d w d v d u d \tau - \frac{2\pi}{L_x L_y L_z^2} \times \\
 & \times \sum_{n=1}^{\infty} n e_{nC}(t) \int_0^t e_{nC}(-\tau) \int_0^{L_x} c_n(u) \int_0^{L_y} c_n(v) \int_0^{L_z} s_n(w) g_L(u, v, w, T) \frac{\partial C_{01}(u, v, w, \tau)}{\partial w} d w d v d u d \tau \times \\
 & \times F_{nC} c_n(x) c_n(y) c_n(z) - \frac{2\pi}{L_x^2 L_y L_z} \sum_{n=1}^{\infty} F_{nC} c_n(x) c_n(y) c_n(z) e_{nC}(t) \int_0^t e_{nC}(-\tau) \int_0^{L_x} s_n(u) \int_0^{L_y} c_n(v) \times \\
 & \times n \int_0^{L_z} c_n(w) \frac{C_{00}^\gamma(u, v, w, \tau)}{P^\gamma(u, v, w, T)} \frac{\partial C_{10}(u, v, w, \tau)}{\partial u} d w d v d u d \tau - \frac{2\pi}{L_x L_y^2 L_z} \sum_{n=1}^{\infty} n F_{nC} c_n(x) c_n(y) \times \\
 & \times c_n(z) e_{nC}(t) \int_0^t e_{nC}(-\tau) \int_0^{L_x} c_n(u) \int_0^{L_y} s_n(v) \int_0^{L_z} c_n(w) \frac{C_{00}^\gamma(u, v, w, \tau)}{P^\gamma(u, v, w, T)} \frac{\partial C_{10}(u, v, w, \tau)}{\partial v} d w d v d u d \tau - \\
 & - \frac{2\pi}{L_x L_y L_z^2} \sum_{n=1}^{\infty} n F_{nC} c_n(x) c_n(y) c_n(z) e_{nC}(t) \int_0^t e_{nC}(-\tau) \int_0^{L_x} c_n(u) \int_0^{L_y} c_n(v) \int_0^{L_z} s_n(w) \frac{C_{00}^\gamma(u, v, w, \tau)}{P^\gamma(u, v, w, T)} \times
 \end{aligned}$$

$$\begin{aligned}
 & \times \frac{\partial C_{10}(u, v, w, \tau)}{\partial w} d w d v d u d \tau - \frac{2\pi}{L_x^2 L_y L_z} \sum_{n=1}^{\infty} n F_{nC} c_n(x) c_n(y) c_n(z) e_{nC}(t) \int_0^t e_{nC}(-\tau) \int_0^{L_x} s_n(u) \times \\
 & \times \int_0^{L_y} c_n(v) \int_0^{L_z} c_n(w) C_{10}(u, v, w, \tau) \frac{C_{00}^{\gamma-1}(u, v, w, \tau)}{P^\gamma(u, v, w, T)} \frac{\partial C_{00}(u, v, w, \tau)}{\partial u} d w d v d u d \tau - \frac{2\pi}{L_x L_y^2 L_z} \sum_{n=1}^{\infty} n \times \\
 & \times F_{nC} c_n(x) c_n(y) c_n(z) e_{nC}(t) \int_0^t e_{nC}(-\tau) \int_0^{L_x} c_n(u) \int_0^{L_y} s_n(v) \int_0^{L_z} c_n(w) \frac{C_{00}^{\gamma-1}(u, v, w, \tau)}{P^\gamma(u, v, w, T)} \frac{\partial C_{00}(u, v, w, \tau)}{\partial v} \times \\
 & \times C_{10}(u, v, w, \tau) d w d v d u d \tau - \frac{2\pi}{L_x L_y L_z^2} \sum_{n=1}^{\infty} n F_{nC} c_n(x) c_n(y) c_n(z) e_{nC}(t) \int_0^t e_{nC}(-\tau) \int_0^{L_x} c_n(u) \times \\
 & \times \int_0^{L_y} c_n(v) \int_0^{L_z} s_n(w) C_{10}(u, v, w, \tau) \frac{C_{00}^{\gamma-1}(u, v, w, \tau)}{P^\gamma(u, v, w, T)} \frac{\partial C_{00}(u, v, w, \tau)}{\partial w} d w d v d u d \tau.
 \end{aligned}$$